

**PC RANGE**

# COMPACT LIGHT-WEIGHT SOLUTIONS BETWEEN ONE AND FOUR METRE TONNES

**LIFETIME EXCELLENCE**



# LIFETIME EXCELLENCE

PALFINGER loader cranes are convincing due to their superior life-cycle performance. They are the most economical and also the most reliable over the entire product life. From solution finding to resale.

- **Better solutions**
- **Better efficiency**
- **Better ergonomics**
- **Higher availability**
- **More reliability**
- **Better ecology**
- **Higher serviceability**
- **Higher value retention**

For further information please visit: [www.palfinger.com/thebrand](http://www.palfinger.com/thebrand)



- High value retention due to coating technology
- Optimum protection thanks to internal oil ducts in the extension cylinders
- Load holding valves prevent the crane boom from dropping
- Extended range of applications thanks to the optional radio remote control and cable winch



# FEATURING MODERN CRANE TECHNOLOGY. THE SMALL CRANE RANGE SETS NEW STANDARDS.

## 12 Highlights



### Slewing mechanism

Maximum performance in minimal space

Greater efficiency thanks to lightweight and maintenance-friendly worm drive. This allows precise slewing of the crane.



### Control console

Communication with the operator

The control console can be positioned as desired and protects the hydraulic control block against damage. In the CE version, PC 2700 and PC 3800 are equipped with a control stand on both sides.

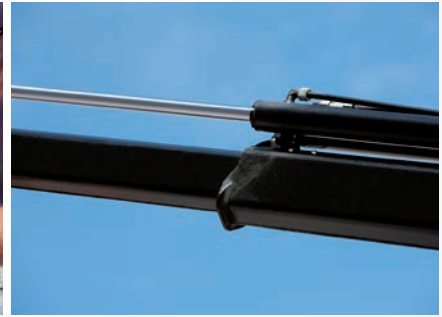

### Internal oil feeds

Maximum protection thanks to compact design

The internal oil ducts enable a compact extension boom system design and ensure maximum protection against damage.

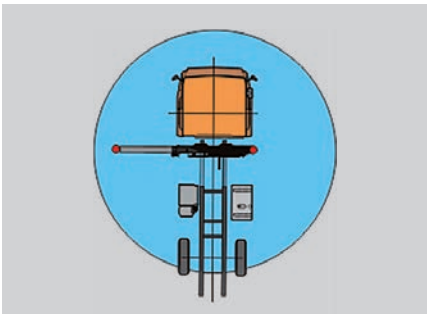

### Stability monitoring system

Easy and safe

In the CE version, PC 2700 and PC 3800 are equipped with a stability monitoring system. The crane can only be operated safely when the outrigger and stabilizers are fully extended.



### Hydraulic overload protection

In-built safety function

In the CE version, PC 2700 and PC 3800 are equipped with hydraulic overload protection. When the load limits are reached, all movements that could further increase the lifting moment are stopped.



### Coating technology

Top quality surface protection at a glance

The KTL coating lays the foundation for a perfect surface protection. Afterwards the components are either coated in the powder-coating facility or are finished with a two-components-topcoat. High value retention and excellent corrosion protection for the whole life of a crane.



**Radio remote control**

Ergonomic one-hand operation

We also offer a proportional remote control for the smallest PALFINGER cranes. Ergonomic, robust and low cost. The control valve and receiver are protected inside a metal case.

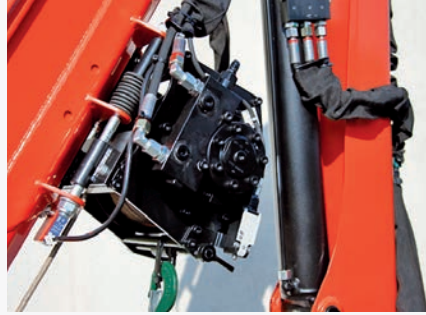

**Cable winch**

The perfect complement

A cable winch vastly increases the potential applications of a PC crane. With a lifting power of 800 kg, it is the ideal solution for small cranes. Also available with an extension stop and limit switch.



**Power packs**

With 1.5 kW or 3.0 kW of power

Specially designed for PC cranes, 12 V or 24 V power packs are available. They are protected inside a robust case and are easy to maintain.



**Stabilizer system BS 008**

For PC 1500 and PC 2700

Designed to achieve optimum stability with a low dead weight. A stability monitoring system for the CE version of PC 2700 is already available for this stabilizer system too.



**Stabilizer system BS 009**

For PC 1500 and PC 2700

Offering a high degree of stability even for small vehicles. The use of different support cylinders enables the stabilizer system to be adapted to the vehicle in an ideal manner.

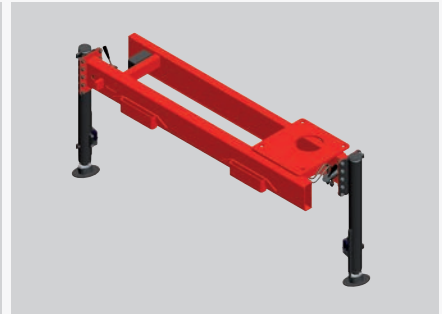

**Stabilizer system BS 010**

For PC 3800

This stabilizer system with a double crossbeam can be supplied either without an outrigger or with one or two outriggers, depending on the body design.

PC 1500

# COMPACT

## EXTENSION BOOM VARIATIONS



m	1.2	2.1	3.1	4.2
kg max.	990	630	440	270

AV1

## DIMENSIONS

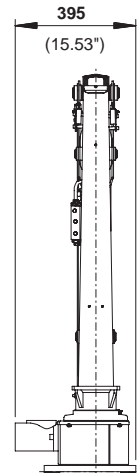
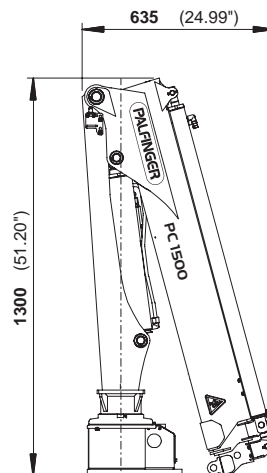
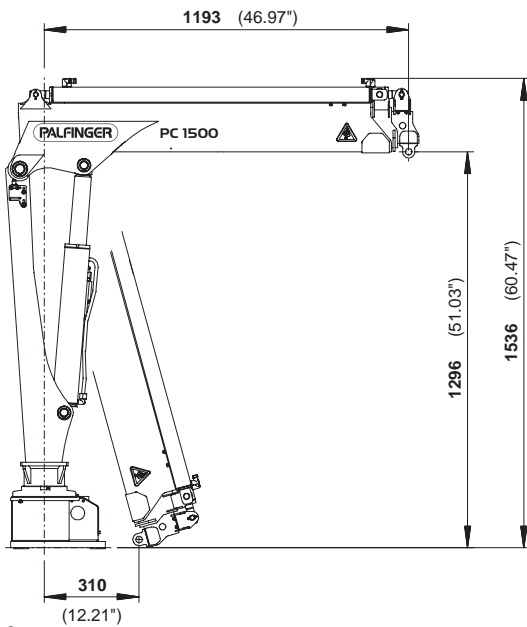

## Technical specifications

### EN 12999 H1-B2

Max. lifting moment	1.4 mt/13,6 kNm	10020 ft. lbs
Max. lifting capacity	990 kg/9,7 kN	2200 lbs
Max. hydraulic outreach	3.1 m	10' 2"
Max. manual outreach	4.2 m	13' 9"
Slewing angle	325°	
Slewing torque	0.20 mt/2.0 kNm	1480 ft.lbs
Fitting space required (std.)	0.40 m	1' 4"
Width folded	0.64 m	2' 1"
Max. operating pressure	200 bar	2900 psi
Recommended pump capacity	6 l/min	1.6 US gal./min
Dead weight (std.)	164 kg	360 lbs



PC 2700

# COMPACT

## EXTENSION BOOM VARIATIONS

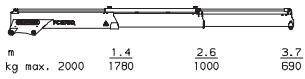

A

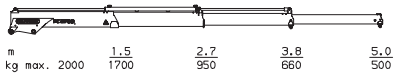

B

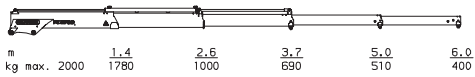

Non-CE – A V2

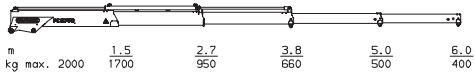

Non-CE – B V1

## DIMENSIONS

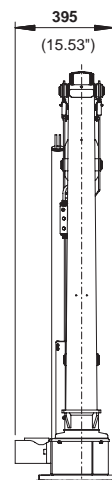
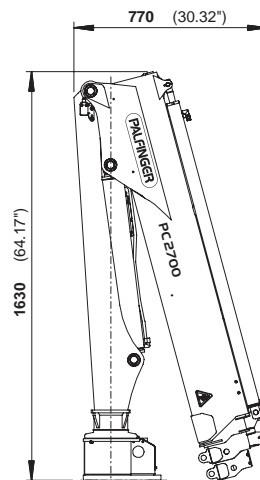
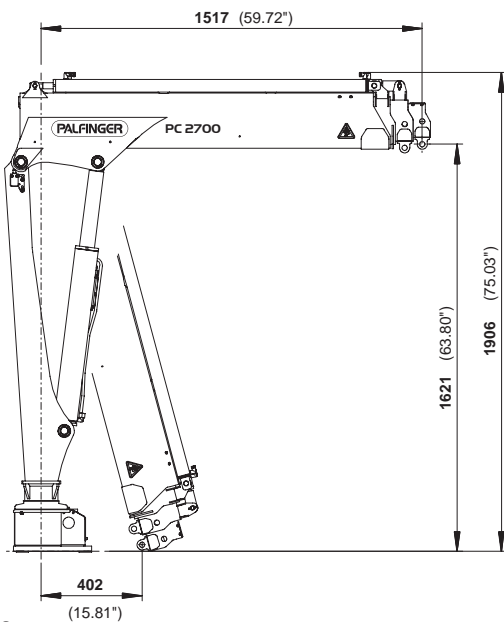



## Technical specifications

### EN 12999 H1-B2

Max. lifting moment	2.6 mt/25.8 kNm	19010 ft.lbs
Max. lifting capacity	2000 kg/19.6 kN	4400 lbs
Max. hydraulic outreach	5.0 m	16' 5"
Max. manual outreach	6.0 m	19' 8"
Slewing angle	325°	
Slewing torque	0.31 mt/3.0 kNm	2210 ft.lbs
Fitting space required (std.)	0.40 m	1' 4"
Width folded	0.77 m	2' 6"
Max. operating pressure	200 bar	2900 psi
Recommended pump capacity	9 l/min	2.4 US gal./min
Dead weight (std.)	207 kg	460 lbs



PC 3800

# COMPACT

## EXTENSION BOOM VARIATIONS

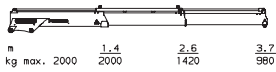

A

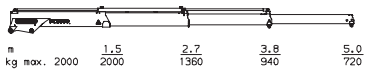

B

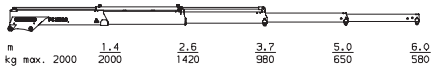

Non-CE – A V2

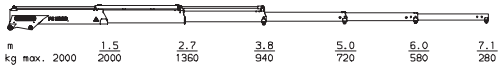

Non-CE – B V1

## DIMENSIONS

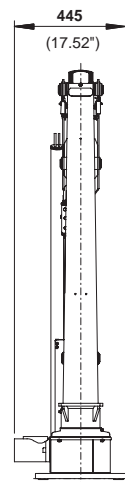
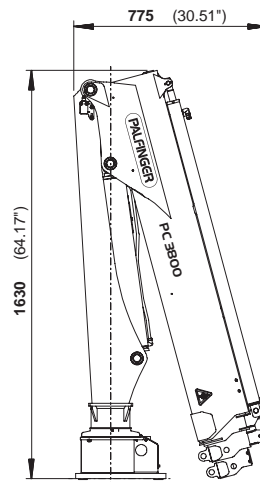
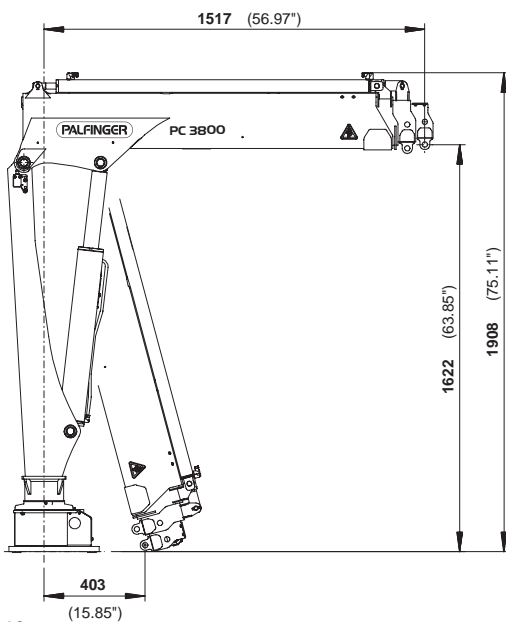

## Technical specifications

### EN 12999 H1-B2

Max. lifting moment	3.7 mt/36.5 kNm	26930 ft.lbs
Max. lifting capacity	2000 kg/19.6 kN	4400 lbs
Max. hydraulic outreach	5.0 m	16' 5"
Max. manual outreach	7.1 m	23' 4"
Slewing angle	325°	
Slewing torque	0.38 mt/3.7 kNm	2730 ft.lbs
Fitting space required (std.)	0.45 m	1' 6"
Width folded	0.77 m	2' 6"
Max. operating pressure	200 bar	2900 psi
Recommended pump capacity	12 l/min	3.2 US gal./min
Dead weight (std.)	238 kg	520 lbs





KP-HPKPCRANGEM2+EN

Cranes shown in the leaflet are partially optional equipped and do not always correspond to the standard version. Country-specific regulations must be observed. Dimensions may vary. Subject to technical changes, errors and translation mistakes.