

MERCEDES

P 250 BK

BENZ SPRINTER 315 CDI 4X2

NUMERO DI CONTRATTO: P250BK STANDARD

NUOVO

IN PRODUZIONE



INFORMAZIONI OFFERTA

Dettagli sulla posizione

Löbau, 02708 - Germania 

Dettagli dealer

Palfinger Platforms GmbH

Tipologia di prodotto

Nuovo

Numero di contratto

P250BK Standard

Email del venditore

sales.platforms@palfinger.com

Telefono del venditore

0049215147920

Produttore	PALFINGER	Dimensioni cesto	1,40 x 0,70 x 1,10 m
Modello	P 250 BK	Capacità di carico	250 kg
Anno di costruzione	NEU - NEW	Rotazione cesto	+/- 90°
Sbraccio	16,9 m	Basket arm angle	185°
Altezza Max. di Lavoro	24,7 m	Materiale cesto	Aluminium
Rotazione torre	500°		
Produttore	Mercedes Benz	Potenza	110 kW (150 PS)
Tipologia di veicolo	Sprinter 315 CDI	Emissioni	EURO 6
Anno di costruzione	NEU - NEW	Assi	4x2
Passo	3.665 mm	PTT	3.500 kg

Working diagrams

Palfinger P 250BK

on

MB Sprinter 3,5t / Iveco Daily 35S

The working diagrams shown below have the following preconditions:

Solid line:

Standard working diagram

Working height = height of basket bottom + 2.0 m

The basket is in basic position (not turned) and retracted

The following applies generally:

All specifications refer to standard aluminum basket without additional equipment

Maximum inclination 0,5°

Set-up inclination is max. 5° with automatic range adjustment.

Note on working diagram:

Additional attachments that deviate from the standard reduce range and basket load

Special baskets have different ranges

Reach at plastic workman basket ~ 0,5m - 0,8m reduced

Permitted maximum basket load according to technical description

The outreaches are approximate dimensions and depend on the chassis, the type of support and the lifting platform's additional equipment.

Illustrations of truck and unit are only of symbolic nature and do not allow any conclusions regarding technical design.

Subject to technical change!

Palfinger P 250BK

Rear view

Extension of stabiliser
outrigger

Front left	100%
Front right	100%
Rear left	100%
Rear right	100%

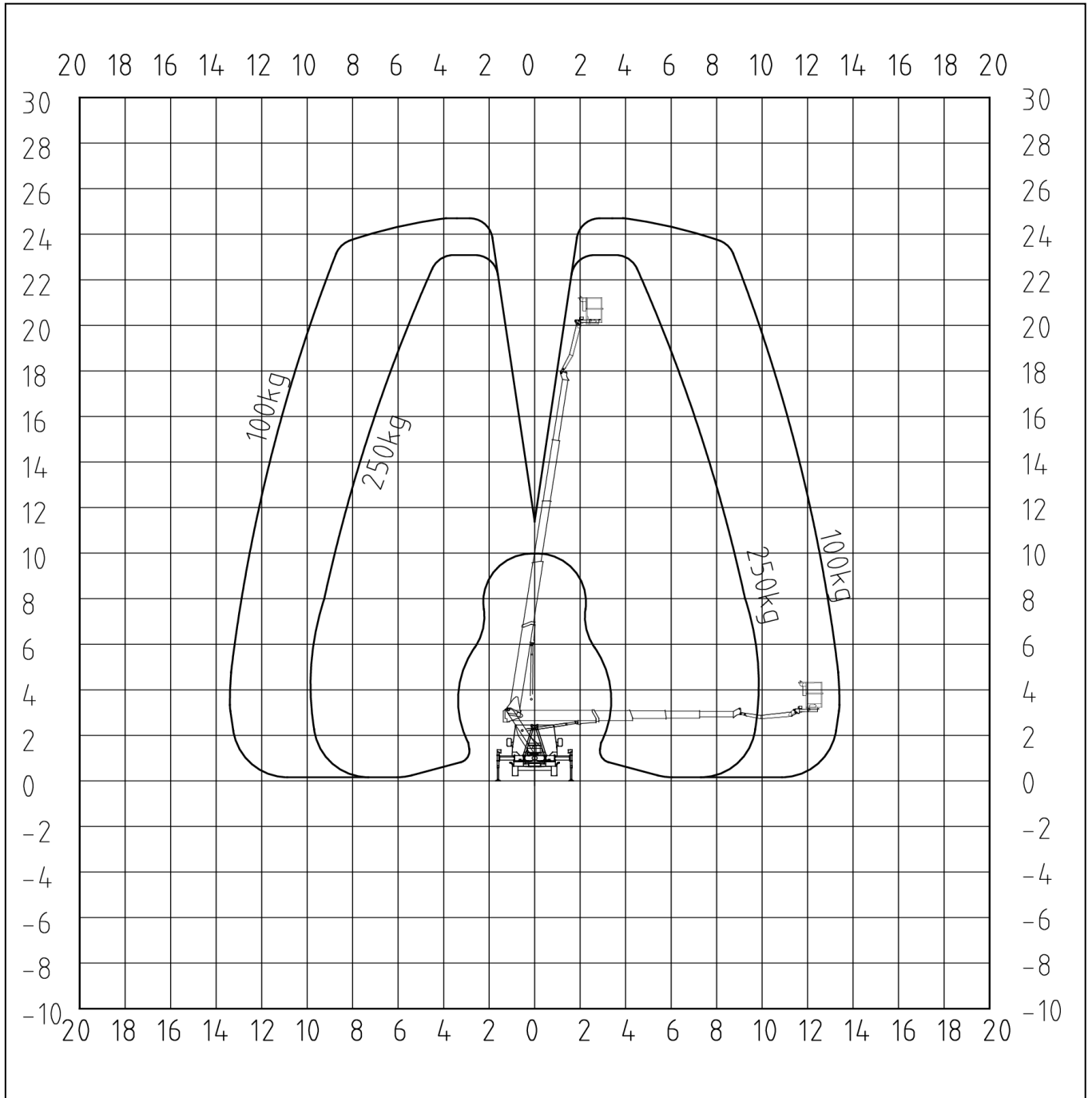

Palfinger P 250BK

Top view

Extension of stabiliser
outrigger

Front left	100%
Front right	100%
Rear left	100%
Rear right	100%

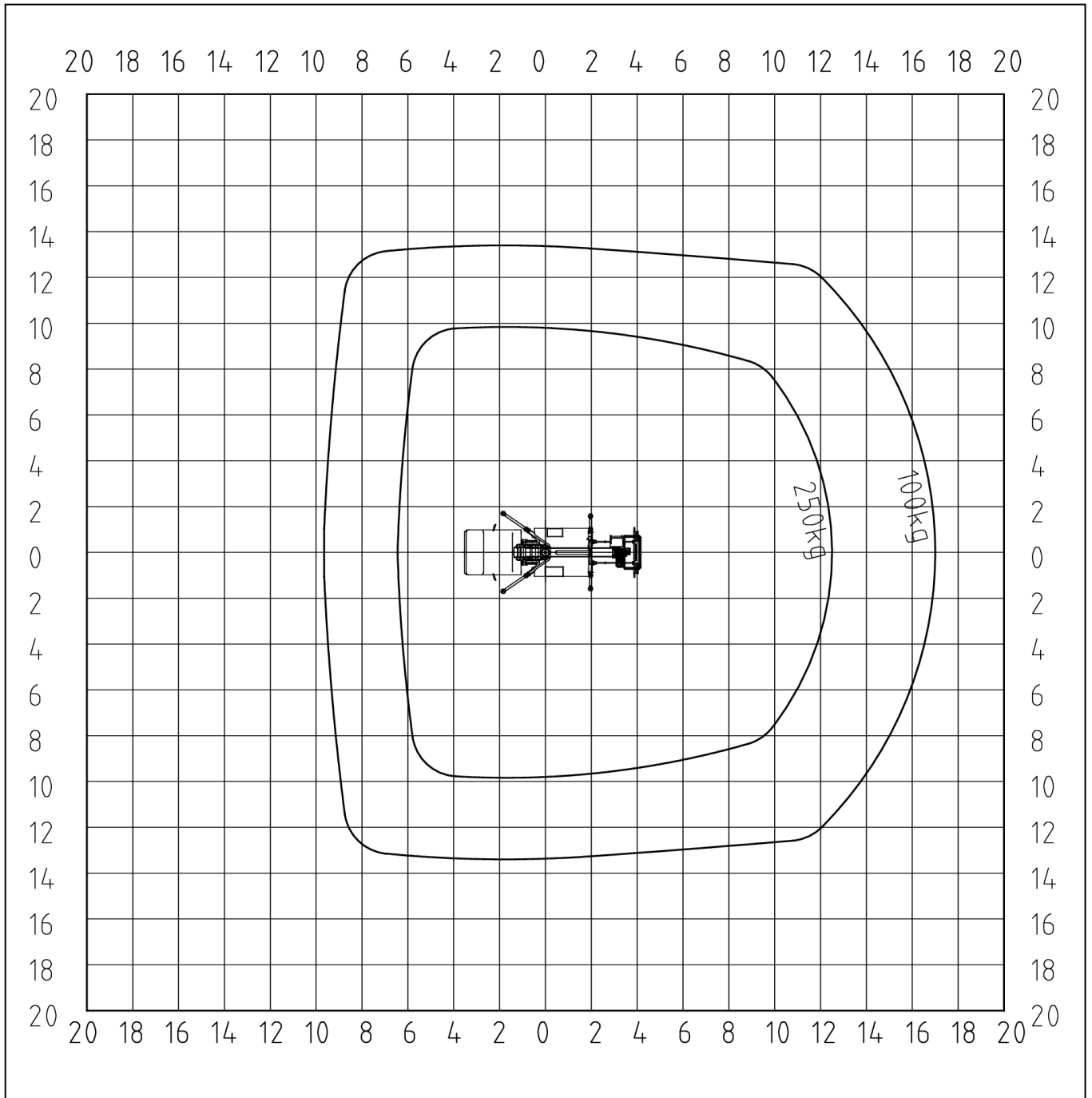

Palfinger P 250BK

Left view

Extension of stabiliser
outrigger

Front left	100%
Front right	100%
Rear left	100%
Rear right	100%

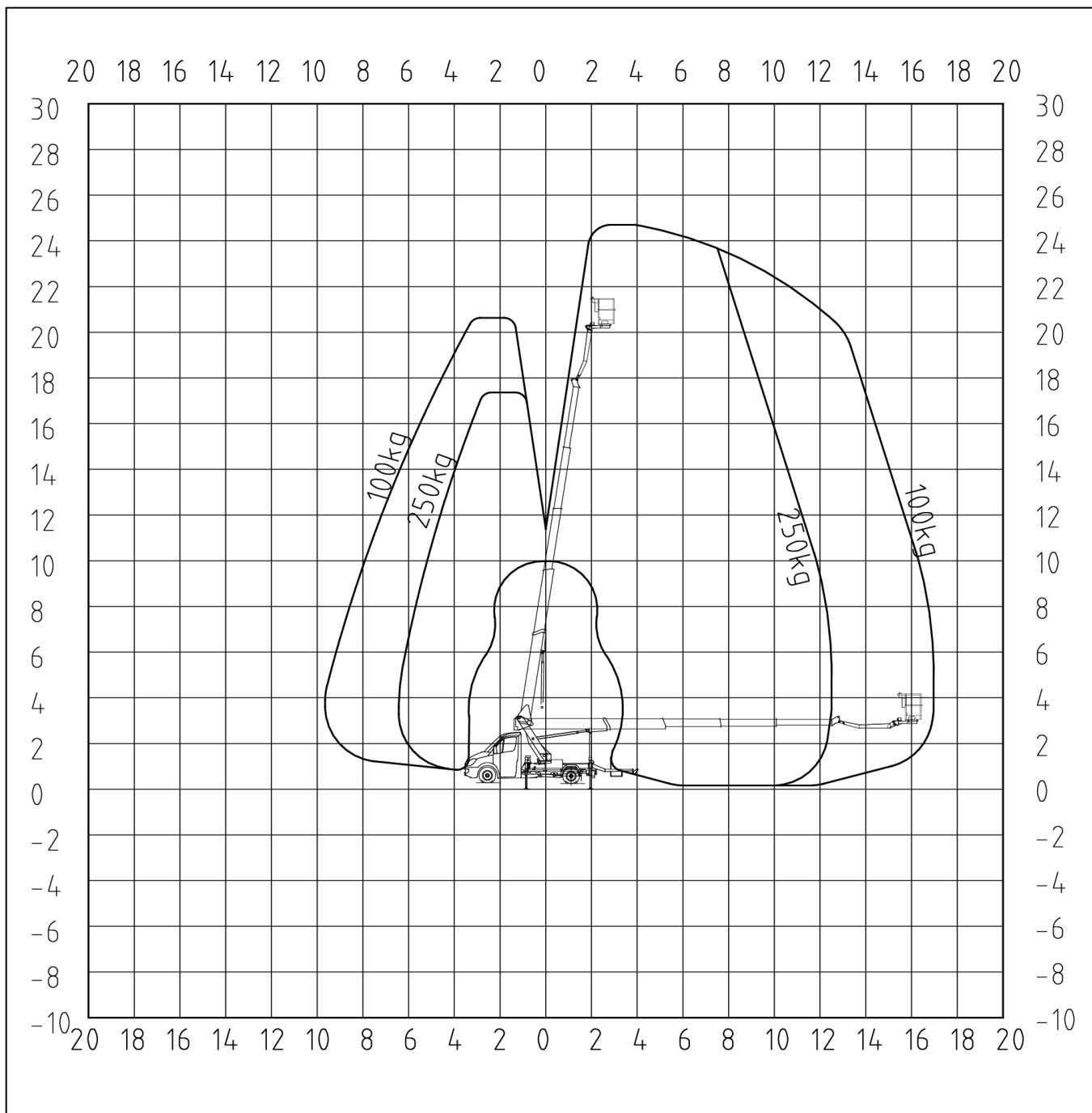

Palfinger P 250BK

Rear view

Extension of stabiliser
outrigger

Front left	0%
Front right	100%
Rear left	0%
Rear right	100%

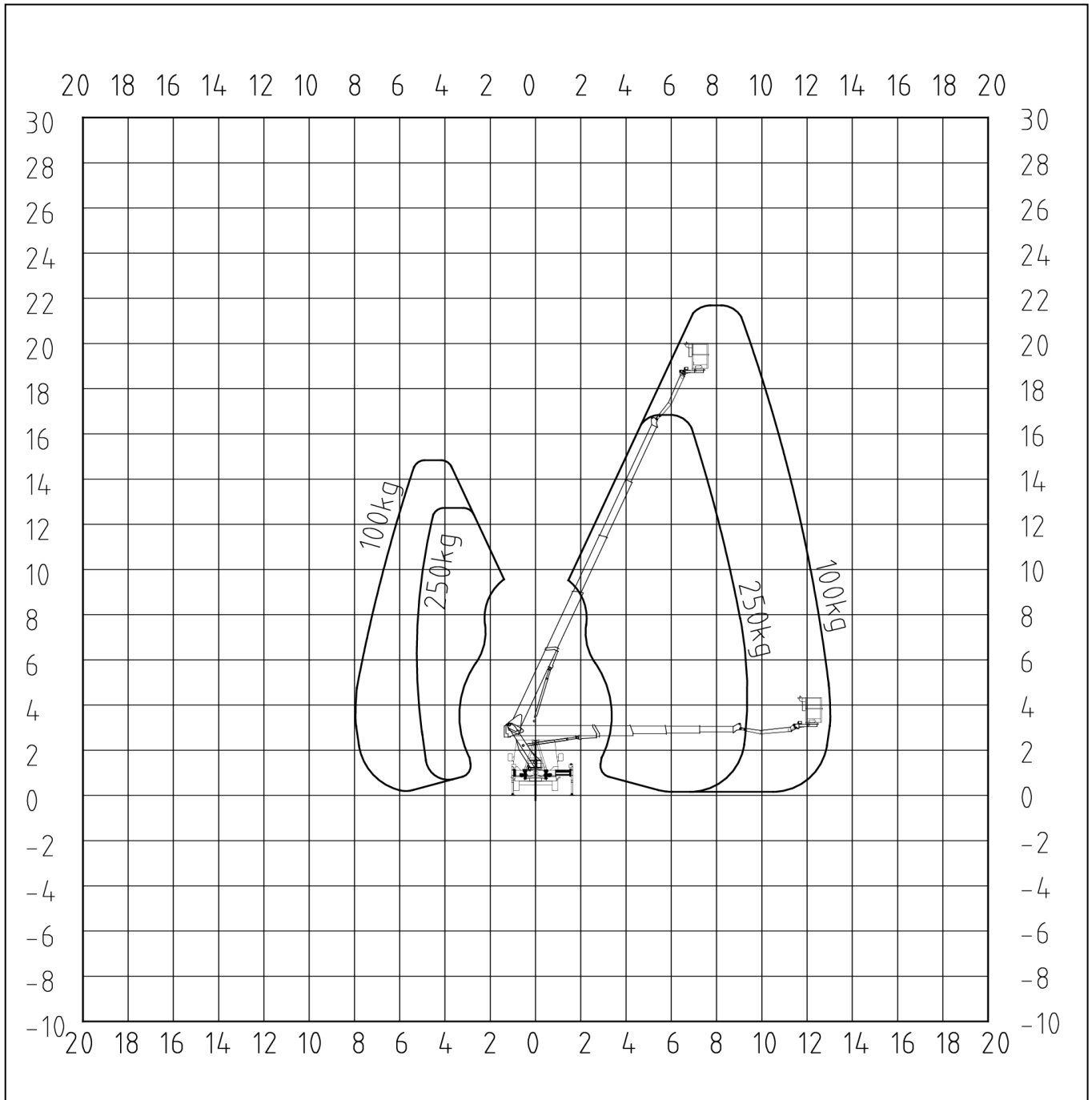

Palfinger P 250BK

Top view

Extension of stabiliser
outrigger

Front left	0%
Front right	100%
Rear left	0%
Rear right	100%

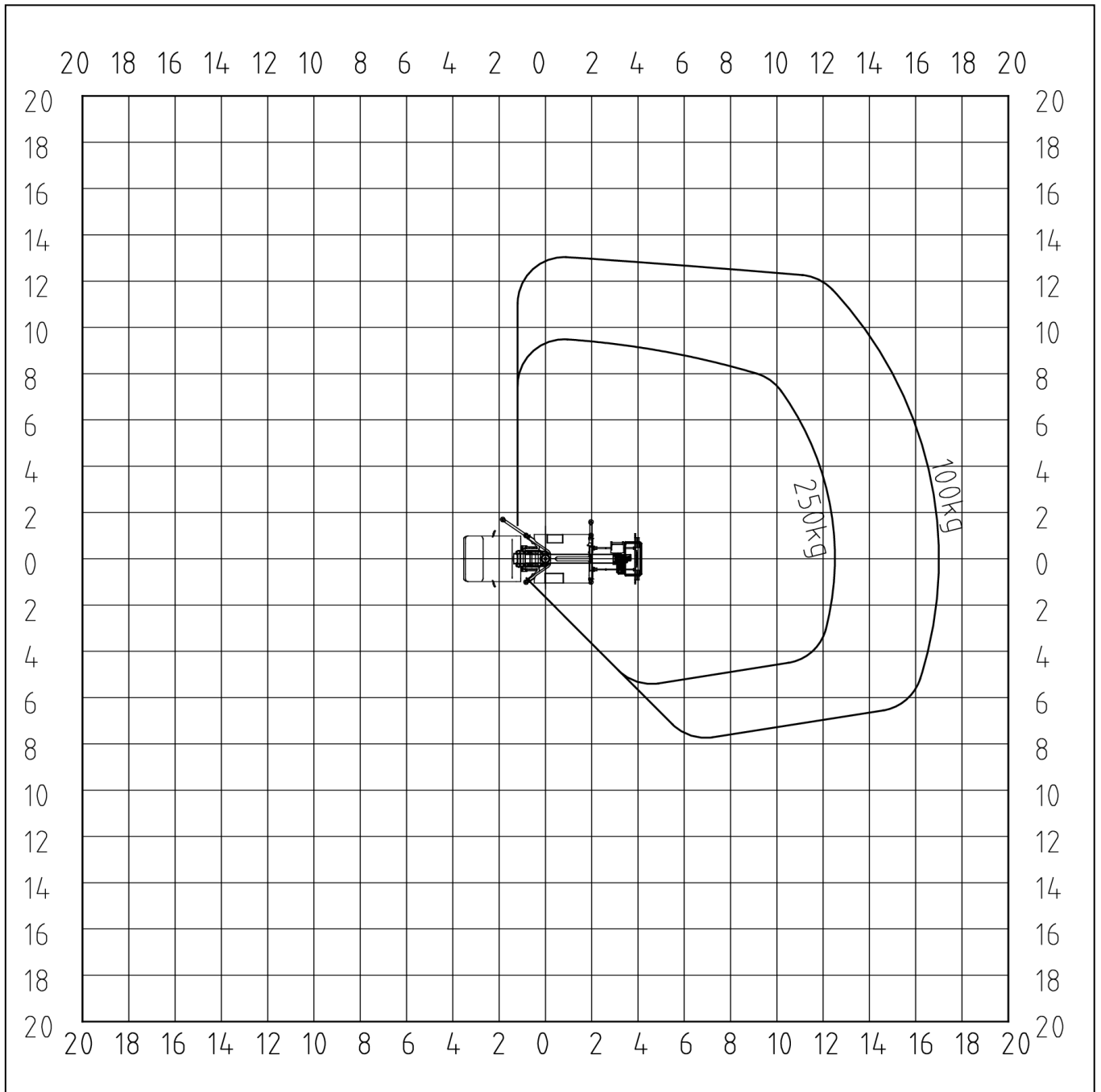

Palfinger P 250BK

Top view

Extension of stabiliser
outrigger

Front left	0%
Front right	0%
Rear left	0%
Rear right	0%

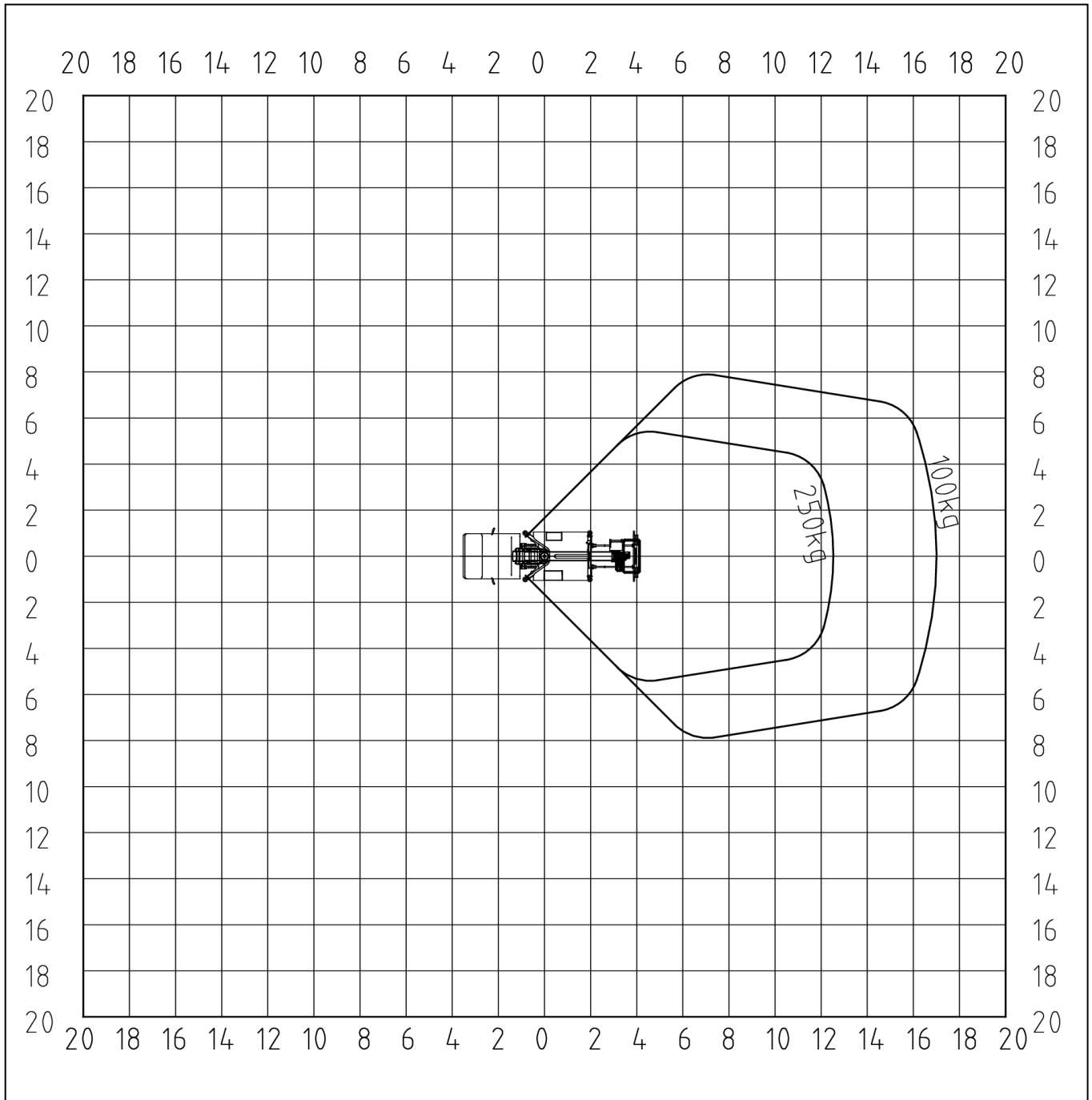

Palfinger P 250BK

Left view

Extension of stabiliser
outrigger

Front left	0%
Front right	100%
Rear left	0%
Rear right	100%

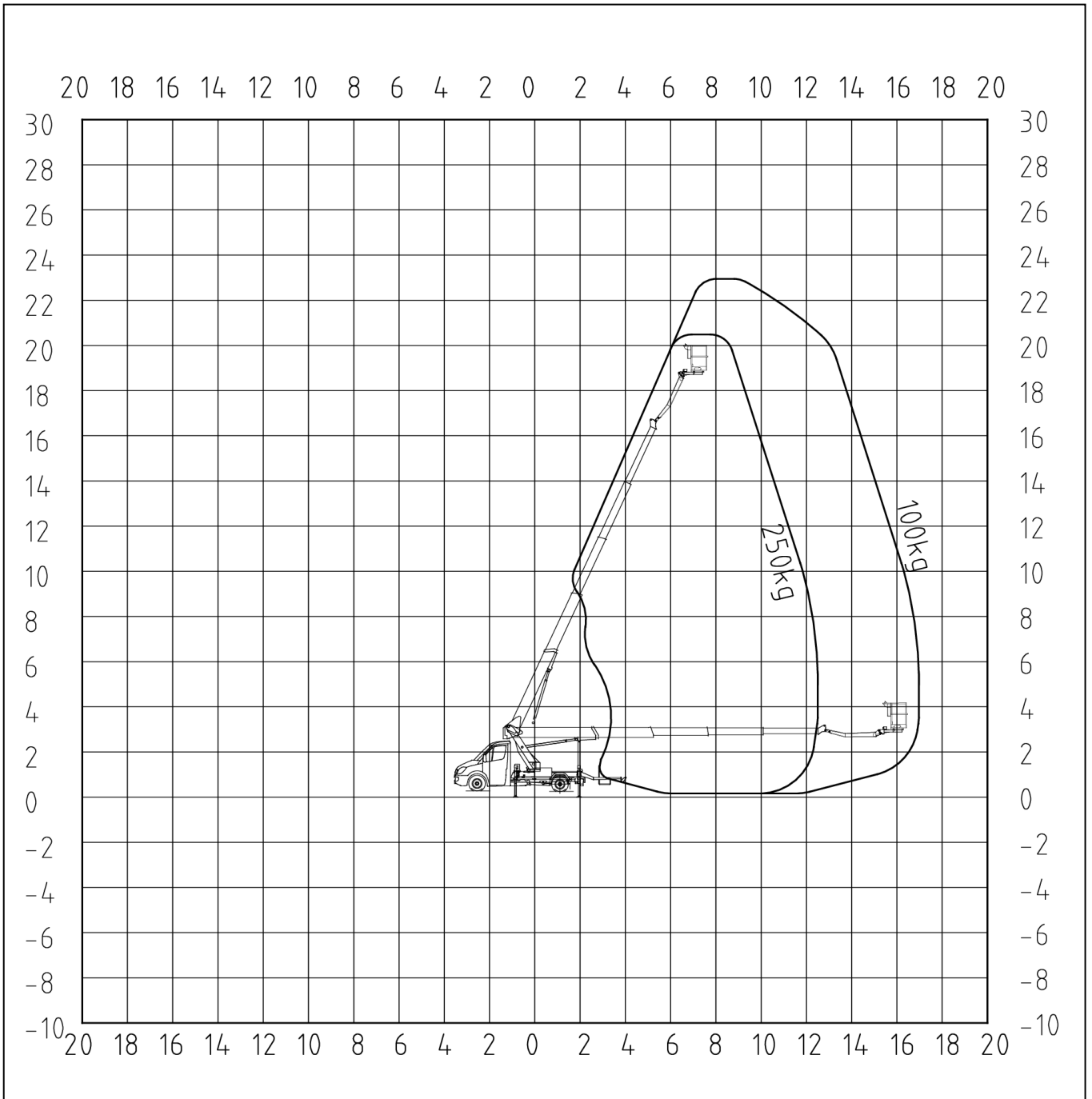

P 250 BK

LIGHTWEIGHT AND VERSATILE

LIFETIME EXCELLENCE

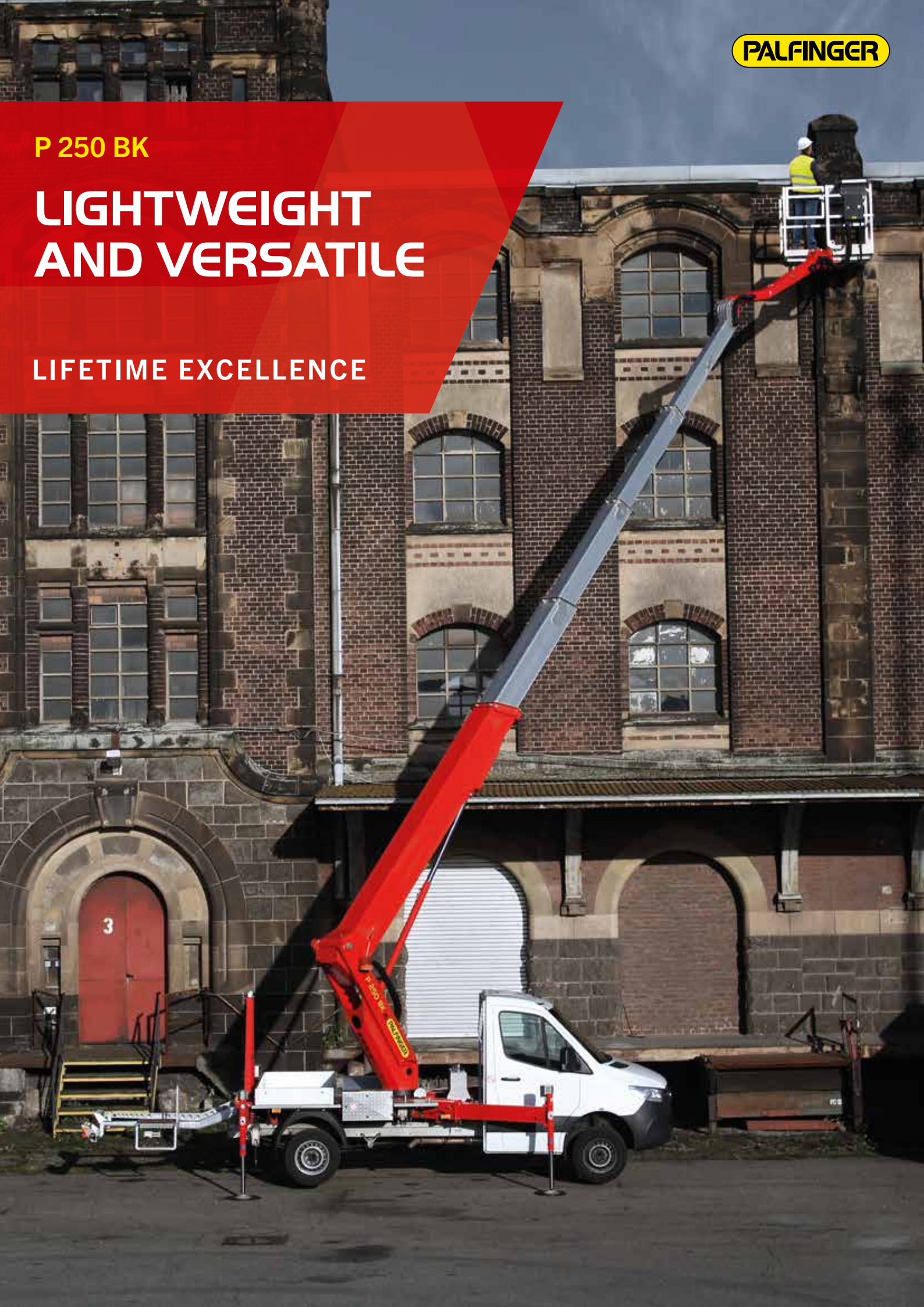

HIGHLIGHTS

- Outrigger control panel located at the rear end for a safe operation. All outriggers are visible from this position.
- The control panel in the cage enables a safe and efficient operation of the platform
- Even with a cage load of 250kg the full working height can be reached.
- Three stabiliser configurations: in contour, fully extended and one side extended only as well as the automatic adjustment of the corresponding working envelope
- Flat substructure under the cage allows users to get close to objects

STANDARDS















- Home function
- Automated positioning system
- 4 Safety plates
- 230V CEE current supply with CEE socket in the workman basket
- European type approval
- Stabilizer control at basis

OPTIONS

- Tree cutting package (tool tray inside the cage, bracket for chainsaw, dividing screen, wooden frame, working lights and illumination of surrounding area)
- Attachment point for load securing nets
- Bracket inclusive 7 traffic cones
- Cable remote control to connect at the base
- Display in addition to the control panel
- Insulation package in combination with aluminum cage



TECHNICAL SPECIFICATIONS

	Total weight *	3390 kg		max. outreach to the side	13.3 m
	Overall length	7.71 m		max. outreach	16.9 m
	Total width	2.22 m		Angle of main boom	500°
	Travelling height	2.99 m		Rotation angle of cage	2 x 90°
	Wheelbase	3665 mm		Rotation angle of cage boom	185°
	max. working height	24.7 m		Size of cage	1.40 x 0.70 x 1.10 m
	max. cage bottom height	22.7 m		max. cage load	250 kg

* Depends on truck chassis

WORKING DIAGRAMS

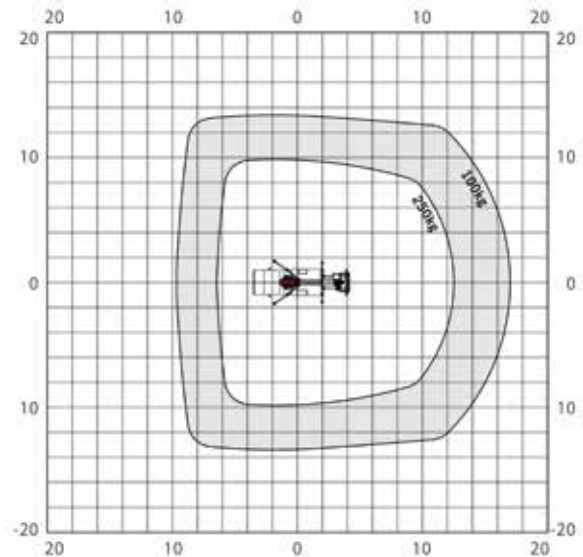
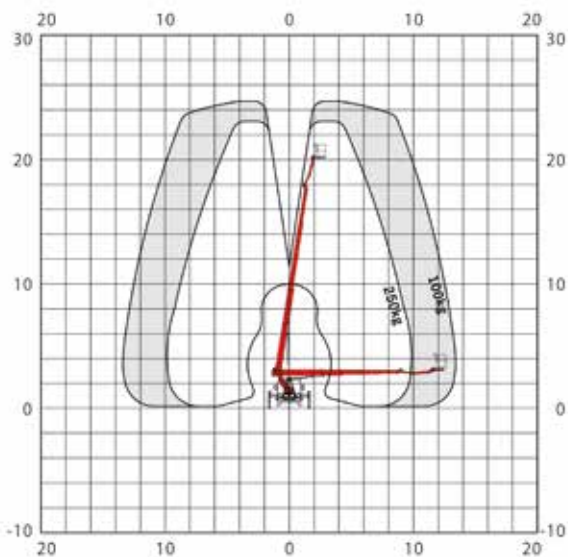

* A possible 2% tolerance is contingent on structural components

DIMENSIONS

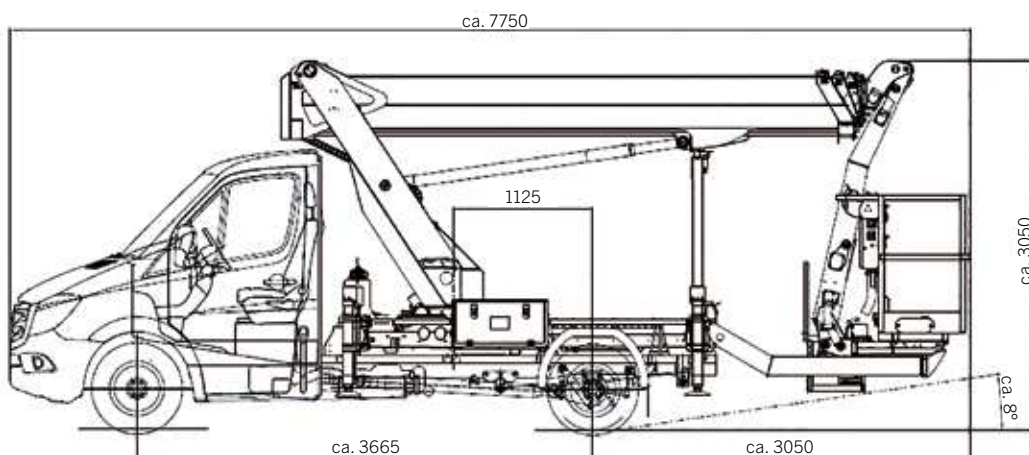

YOUR CONTACT

Palfinger Platforms GmbH

Düsseldorfer Str. 100
47809 Krefeld | Germany

KP-P250BKM3+EN

Units shown in the leaflet are partially optional equipped and do not always correspond to the standard version. Country-specific regulations must be observed. Dimensions may vary. Subject to technical changes, errors and translation mistakes.

VEHICLE DESCRIPTION**P 180 BK, P 220 BK, P 250 BK,
P 280 B****MERCEDES-BENZ SPRINTER 315 CDI****LIFETIME EXCELLENCE**

Chassis with Cab	
Basic vehicle Number	90713313
Vehicle	Sprinter Chassis 315 CDI standard
Engine Power	110 kW (150PS)
wheelbase	3665 mm
Steering layout	left
Total weight	3500 Kg
Drive	RWD



Equipment Mercedes-Benz Sprinter 315 CDI 4x2 BB		
Vehicle-Characteristics		
Lines, Packages, Variants	Standard	IG4
	Basic	IG5
Chassis	Axle ratio i = 4.182	AR3
	Front axle with increased load capacity	A50
	Stabilization level II	CB8
	Tires (make not specified)	RD9
	Tires 235/65 R16 C	RH2
	All-season tires	RM0
	Steel wheels 6.5 J x 16	RS3
	premium protection tires (3 years)	Z3R
	Without load uprating/derating 3,500 kg	XG7
Engines and transmission	Engine OM 654 DE 20 LA 110 kW (150 hp) 3800 rpm	MU3
	Engine version Euro VI	MP6
	Exhaust gas level E	MR0
	ECO Gear 360 6-speed manual transmission	GD8
	PTO counter shaft MB, (2c)	*N05
	Locking mechanism for power take-off	N80
	Main tank: 71 liters	K13
Bodies and attachments	Exterior mirror, heated and electrically adjustable	F68
	Interior mirror	F61
	Longitudinal member reinforcement	Q11
	Omission of end cross member	Q72
	End outline marker lights	L07

Equipment Mercedes-Benz Sprinter 315 CDI 4x2 BB		
Bodies and attachments	Omission of parking lights	L94
	Side marker lights	LB1
	Pre-fitting for rotating beacon lamp	LV1
	Adaptive brake light	LE1
	Rear-wall window	F35
	Heat-insulating glass with bandpass filter on windshield	H21
	Rear towing eye	Q67
	Omission of vehicle lowering	CW2
	Front mud flaps	P47
Interior equipment, heating and air-conditioning	Driver's seat	S02
	Adjustable co-driver's seat	S04
	Armrest for driver's seat	S22
	Armrest for co-driver's seat	S25
	Airbag, front driver's seat	SA5
	Seat belt warning for passenger seat	J55
	Shelf above windshield	FF5
	Stowage compartment under cockpit	FJ4
	First aid kit	Y10
	Warning triangle	Y44
Radio, instruments and electrics	Digital Radio (DAB)	E1D
	MB audio system	E1O
	AGM battery 12 V 70 Ah	ED1
	Jump start contact	ES0

Equipment Mercedes-Benz Sprinter 315 CDI 4x2 BB		
Radio, instruments and electrics	Generator 14 V / 250 A	M60
	Parameterizable special module	ED5
	Terminal strip for electrical connection	EK1
	Seat belt warning for driver's seat	J58
	Speedometer, km/h	J10
	Height- and rake-adjustable steering wheel	CL1
	Outside temperature indicator	J65
	Crosswind Assist	JA8
	Communication module (LTE) for digital services	JH3
	Pre-fittings for multi-tone horn unit	JV7
	Headlight assistant	LA2
	Constant speed control	M53
	Omission of the eco-start-stop function	MI9
Further equipment	Production in Ludwigsfelde	Z4W
	ECE version	Z52
	Bodyshell, additional measures	Z75
	Plates/booklets (in German)	XU1
	Registration certificate, Part II, prepared	X31
	COC papers, incomplete	XC1
	Reference mass of at least 2,381 kg required	XV1
	Qualification N1	Z1N
	4th generation SCR emission control system	KP7
	control code, change over WLTP	XW9

Equipment Mercedes-Benz Sprinter 315 CDI 4x2 BB		
Further equipment	Model generation 0	XZ0
	National version for EU – EFTA-UK	*Z2E
Connectivity Solutions	Mercedes-Benz demergency call system	EY5
	Breakdown management	EY6
Upholstery	Fabric: Maturin black	VF7
Note	Execution according to order confirmation	

*Technical changes and errors excepted

YOUR OFFER



YOUR REQUESTED SPECIFICATION

EQUIPMENT



P250BK-STD - PALdrive P 250 BK for MB 315/317

Palfinger platform P 250 BK prepared for Mercedes Benz Sprinter 3xx

- Working height approx.. 24,70 m
- Cage floor height approx. 22,70 m
- Max. outreach 16,90 m
- Max. cage load 250 kg
- Max. swivel range turntable 500 °
- Dimensions of cage (W x D x H) aprox. 1,40 x 0,70 x 1,10 m
- Swivel range of cage aprox. +/- 90°
- Max. permissible inclination 5°
- Reduction of outreach 0,5 °
- Swivel within mirrors width
- Anodized extrusion-moulded aluminum telescopes, Telescopic cylinder in protected position where easy to maintain and prevented from damage of collision
- Aluminum Cage
- Fixed aluminum bordering 200mm high mounted on the rear cover
- Covers made of aluminum chequer plate
- Stabilizer control panel at the base and in the Cage
- Electronic emergency control of the platform via display at the base
- Free programmable height Limitation
- Display in Addition to the control Panel in the Cage
- Engine start/stop at the base and in the cage
- Modern modular cage control panel with robust cover
- Automatic stabilizer levelling System
- Main movements can be carried out variably via two joysticks, up to four movements simultaneously
- Easy-to-clean membrane buttons; very easy to replace when dirty or damaged
- LED strip to indicate the operating Status
- Homefunction incl. stabilisers at the base and in the Cage
- Sensitive electronic controlled proportional Regulation
- Automatic cage assistant function
- Soft cage levelling
- Hydraulic cage rotation with automatic detection of middle Position
- Crush protection in the Cage
- Signal Lights fix installed on both sides of the column
- 230V CEE-socket incl. supply with residual current circuit breaker at the base
- Additional CEE-socket supplied by on-board voltage
- Cleaning hatch in the Cage
- Self-closing door for upright entrance to the Cage
- 2 anchor points for safetyharnesses
- Battery voltage Monitoring
- Painting in MB 9147- arctic White
- PALDiag for system analysis, integrated in platforms Software
- Palfinger Connected telematic module
- Documentation (Prüfbuch) and operation manual in German
- Stickers in German language

- CE-certificate
- Type approval according 2007/46/EG incl. EC-Certificate of Conformity

**MBSR35-STD - MB Sprinter 315 - Standardconfiguration**

- Wheelbase 3665 mm
- Gross weight 3.500 kg
- Rear-wheeldrive
- Diesel engine 110 kW (150 PS) 3800/min
- OBD (On Board Diagnostics) Step D
- Reinforced starter
- 6-speed manual transmission ECO Gear 360
- PTO countershaft MB, (2c)
- Gear lock for PTO
- Exhaust gas purification SCR Generation 3
- Fuel tank 71 Liter
- Axle ratio $i = 3,923$
- Front axle with increased payload stabilization Stufe II
- 235/65 R16 C all-season tyres
- Steel wheels 6,5 J x 16
- Exterior mirror, heated and electrically adjustable
- Interior mirror
- Adaptive brake light
- Rear-wall window
- Heat-insulating glass with bandpass filter on windshield
- Adjustable driver's seat
- Seat belt warning for passenger seat
- Adjustable co-driver's seat
- Upholstery fabric Maturin schwarz
- Armrest for driver's seat
- Armrest for co-driver's seat
- Driver's airbag
- Shelf above windshield
- Stowage compartment under cockpit
- Warning triangle
- Digital Radio (DAB)
- MB audio system with Bluetooth®
- AGM battery 12 V 70 Ah
- Jump start contact
- Generator 14 V/ 180 A
- Parameterizable special module
- Speedometer km/h
- Height- and rake-adjustable steering wheel
- Outside temperature indicator
- Crosswind Assist
- Communication module (LTE) for digital services
- Pre-fittings for multi-tone horn unit
- Headlight assistant
- Omission of the eco-start-stop function

- Mercedes-Benz emergency call System
- Driver's cab MB 9147- arctic white

PREVIEW

Platforms | Area sales Manager



Head of sales
Michael Gruböck



Laura Garagnani
Responsible Areas:
France, Portugal, Spain



Timo Lenzen
Responsible Areas: Norway, Sweden, Finland, Island, Denmark, Faroe Islands, Latvia, Lithuania, Estonia, Czech Republic, Poland, Ukraine, Moldova



Adnan Isso
Responsible Areas:
Netherlands, Belgium, Luxembourg



Mohammed AlNajmi
Responsible Areas: Slovenia, Croatia, Greece, Cyprus, Serbia, Bosnia, Kosovo, Montenegro, Albania, Macedonia, Israel, Turkey, Georgia, Syria, Lebanon, Jordan, Iraq, Iran, Afghanistan, Saudi Arabia, Kuwait, Bahrain, Qatar, UAE, Oman, Yemen



Dieter Schlosser
Responsible Areas:
Switzerland, Slovakia, Hungary, Romania, Bulgaria, Australia, New Zealand, Georgia, Ireland, United Kingdom



Johann Poschner
Responsible Areas:
Germany, Austria



ALFREDO CAREDDU
Responsible Areas:
Italy, Malta



Mohammed AlNajmi
Responsible Areas:
Africa

