

MERCEDES

P 250 BK

BENZ SPRINTER 315 CDI 4X2

NÚMERO DE REFERENCIA: P250BK STANDARD

NUEVO

EN PRODUCCIÓN



INFORMACIÓN DEL PRODUCTO

Información del lugar

Löbau, 02708 - Alemania 

Vendedor

Palfinger Platforms GmbH

Tipo de Producto

Nuevo

Número de Referencia

P250BK Standard

Email

sales.platforms@palfinger.com

Teléfonos de Contacto

004935854796121

PRODUCTO

Fabricante	PALFINGER	Dimensión cesta	1,40 x 0,70 x 1,10 m
Modelo	P 250 BK	Capacidad de carga	250 kg
Año	NEU - NEW	Rotación cesta	+/- 90°
Alcance lateral	16,9 m	Rotación de la Torre	185°
Altura de Trabajo	24,7 m	Material Cesta	Aluminium
Rotación columna	500°		

CAMIÓN

Fabricante	Mercedes Benz	Power	110 kW (150 PS)
Tipo de Vehículo	Sprinter 315 CDI	Emisiones	EURO 6
Año	NEU - NEW	Axes	4x2
DEE (mm)	3.665 mm	Masa Máxima Autorizada	3.500 kg

P 250 BK

LIGHTWEIGHT AND VERSATILE

LIFETIME EXCELLENCE

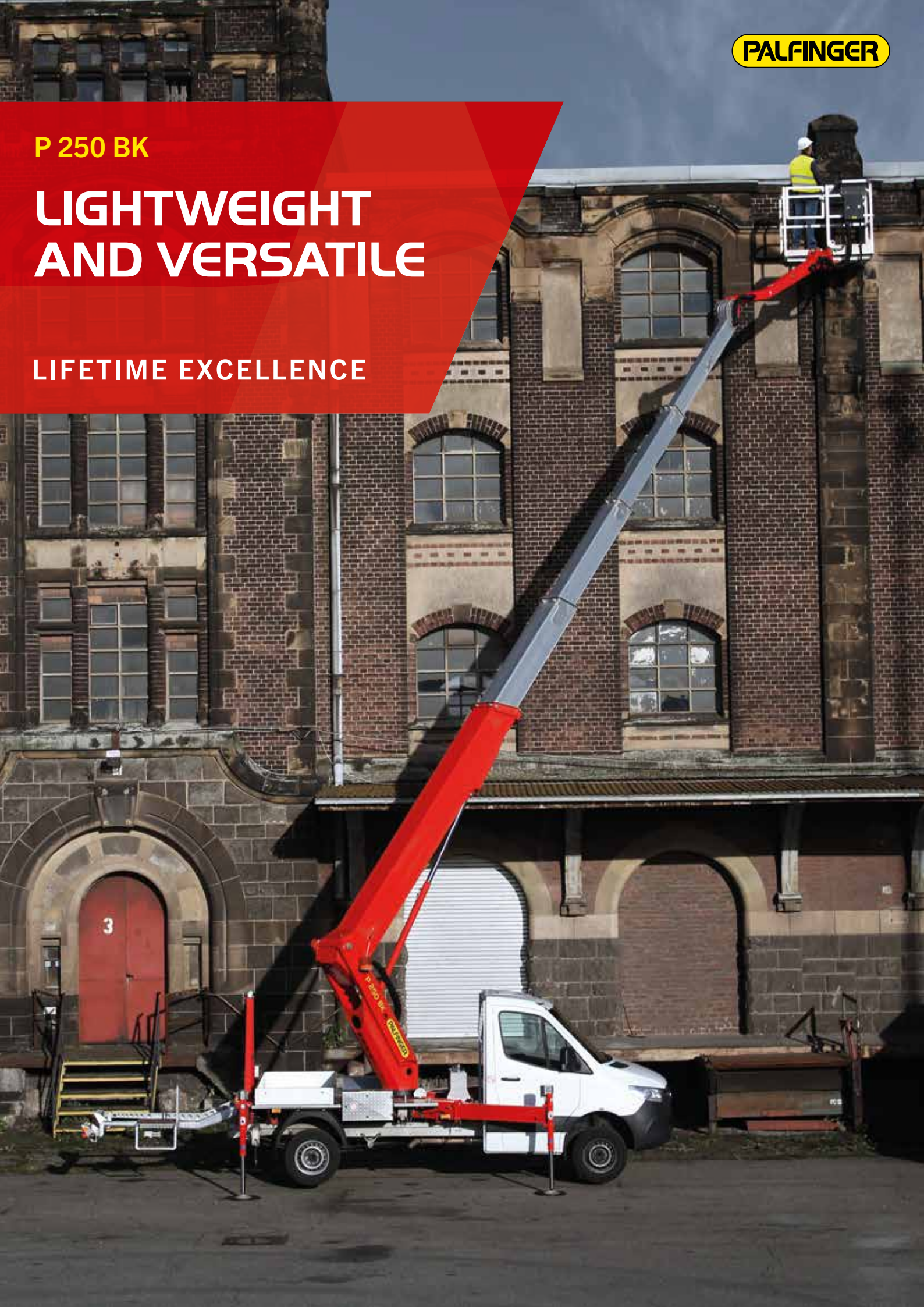

HIGHLIGHTS

- Outrigger control panel located at the rear end for a safe operation. All outriggers are visible from this position.
- The control panel in the cage enables a safe and efficient operation of the platform
- Even with a cage load of 250kg the full working height can be reached.
- Three stabiliser configurations: in contour, fully extended and one side extended only as well as the automatic adjustment of the corresponding working envelope
- Flat substructure under the cage allows users to get close to objects

STANDARDS















- Home function
- Automated positioning system
- 4 Safety plates
- 230V CEE current supply with CEE socket in the workman basket
- European type approval
- Stabilizer control at basis

OPTIONS

- Tree cutting package (tool tray inside the cage, bracket for chainsaw, dividing screen, wooden frame, working lights and illumination of surrounding area)
- Attachment point for load securing nets
- Bracket inclusive 7 traffic cones
- Cable remote control to connect at the base
- Display in addition to the control panel
- Insulation package in combination with aluminum cage



TECHNICAL SPECIFICATIONS

	Total weight *	3390 kg		max. outreach to the side	13.3 m
	Overall length	7.71 m		max. outreach	16.9 m
	Total width	2.22 m		Angle of main boom	500°
	Travelling height	2.99 m		Rotation angle of cage	2 x 90°
	Wheelbase	3665 mm		Rotation angle of cage boom	185°
	max. working height	24.7 m		Size of cage	1.40 x 0.70 x 1.10 m
	max. cage bottom height	22.7 m		max. cage load	250 kg

* Depends on truck chassis

WORKING DIAGRAMS

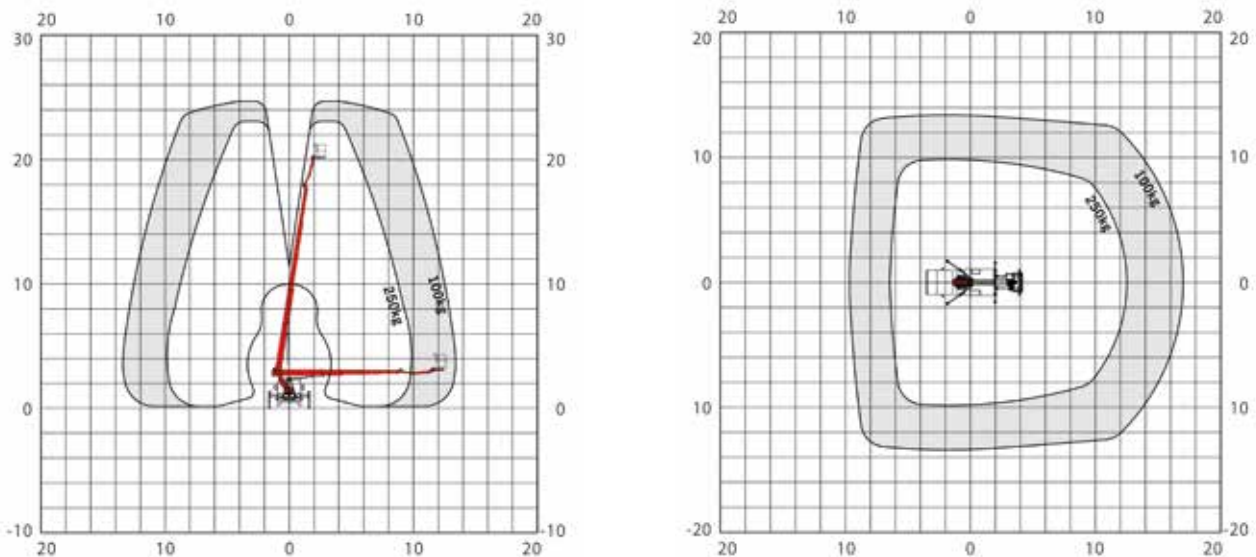

* A possible 2% tolerance is contingent on structural components

DIMENSIONS

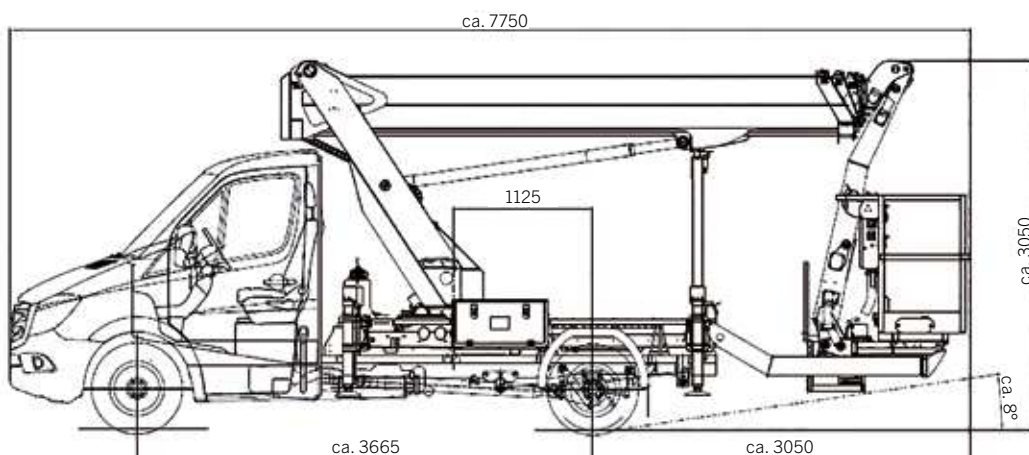

YOUR CONTACT

Palfinger Platforms GmbH

Düsseldorfer Str. 100
47809 Krefeld | Germany

KP-P250BKM3+EN

Units shown in the leaflet are partially optional equipped and do not always correspond to the standard version. Country-specific regulations must be observed. Dimensions may vary. Subject to technical changes, errors and translation mistakes.

Platforms | Area sales Manager



Head of sales
Michael Gruböck



Laura Garagnani
Responsible Areas:
France, Portugal, Spain



Timo Lenzen
Responsible Areas: Norway, Sweden, Finland, Island, Denmark, Faroe Islands, Latvia, Lithuania, Estonia, Czech Republic, Poland, Ukraine, Moldova



Adnan Isso
Responsible Areas:
Netherlands, Belgium, Luxembourg



Mohammed AlNajmi
Responsible Areas: Slovenia, Croatia, Greece, Cyprus, Serbia, Bosnia, Kosovo, Montenegro, Albania, Macedonia, Israel, Turkey, Georgia, Syria, Lebanon, Jordan, Iraq, Iran, Afghanistan, Saudi Arabia, Kuwait, Bahrain, Qatar, UAE, Oman, Yemen



Dieter Schlosser
Responsible Areas:
Switzerland, Slovakia, Hungary, Romania, Bulgaria, Australia, New Zealand, Georgia, Ireland, United Kingdom



Johann Poschner
Responsible Areas:
Germany, Austria



ALFREDO CAREDDU
Responsible Areas:
Italy, Malta



Mohammed AlNajmi
Responsible Areas:
Africa

