

PAL Pro 39 Mechanics Truck Ford 2018 Ford



F-550 XL

FORD

PAL PRO 39 MECHANICS TRUCK

2018 FORD F-550 XL

STOCK NUMBER: C56410

MECHANICS TRUCK

AVAILABLE



OFFER INFORMATION

Location details

145 E, 350 N Fwy Service Rd, Fairfield, TX, 75840 -
United States 

Dealer details

Freestone Chrysler Jeep Dodge | Contact: Heather
Schick

Dealer E-mail

heather@freestonechryslerjeepdodge.com

Dealer phone

1-903-390-2978

Availability

Available

Product type

Mechanics Truck

Stock number

C56410

CRANE BODY TECHNICAL DETAILS

- 44" standard compartment heights with 60" raised compartment on curbside
- 11' Mechanics body
- Treadplate cargo floor, load space walls and compartment tops
- Hybrid torsion box and ladder frame
- Palfinger engineered internal gussets prevents body cracking
- Full length channel drip rails
- Double panel doors with internal C-channel stiffeners, adhered with structural adhesive
- Non-marring boom rest

SERVICE CRANE TECHNICAL DETAILS

- PSC 6025H Hydraulic crane
25' Reach
Momentum rating 38,500 Ft/lbs
- Wireless Remote Standard
 - 400 degree Rotation
 - 6000# Capacity
 - WINCH Hydraulic planetary winch standard for speed, durability, and higher duty cycle. Boom mounted winch for consistent line length when raising or lowering boom.
 - E-Coat Process

[PSC 6025 Brochure Download](#)

- Workbench featuring 21" bumper, receiver hitch, 1/4" steel top plate and thru compartment
- Linear adjustable front mounts
- Aluminium doors and hinges
- Rubber mounted LED lights
- E-coat primer
- Full Hydraulic Outriggers up and down/out

[PAL Pro 39 Brochure Download](#)

[COMPRESSOR TECHNICAL DETAILS](#)

Palfinger PRC 45v Rotary screw air compressor:

-45 CFM @ 150 PSI

-100% duty cycle

-Cold Start Protection

[CHASSIS DETAILS](#)

- 2018 Ford D-550 Chassis XL Truck Regular Cab

F-550 XL

-200 PSI Air pressure relief

valve

-Automatic air pressure

blowdown

-Integrated hydraulic oil and

air coolers

-High temperature shutdown

-Limited Lifetime warranty

-1/2" x 50' Air hose reel

located in curbside rear

vertical compartment and

routed through rear wall with

guide

-1/2" moisture separator/

regulator/oiler

-6 Gallon air reservoir

mounted between frame rails

at rear

MECHANICS BODY PAL Pro 39

Mechanics Bodies, Service Cranes & Compressors
Built for the Modern Work Truck.

LIFETIME EXCELLENCE





With the best equipment for the job, add a competitive edge to your business in a range of industries. Our mechanics trucks are a reliable partner in: Construction, Roadway, Railway, Agriculture, Oil & Gas, Mining, Utilities and Municipalities.

Add one of our light weight, long reach, and increased lifting capacity cranes, and our lightest in the industry rotary screw hydraulic compressors and you have the strongest, lightest 39,000 ft lbs capacity crane package.

APPLICABLE CRANE MODELS

- PSC 3216
- PSC 4016
- PSC 4025
- PSC 5025
- PSC 6025

APPLICABLE COMPRESSORS

- PRC 45V
- PRC 60V

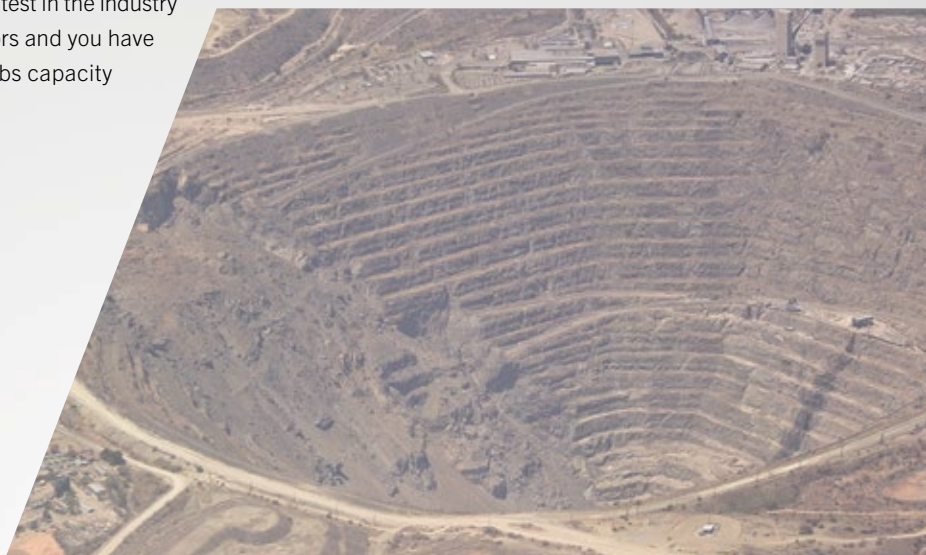

HIGHLIGHTS

Extending the PALFINGER range of mechanics bodies, the PAL Pro 39 is a weight optimized mechanics body available in 9' or 11' configurations. With light-weight aluminum doors and shelving, the PAL Pro 39 offers more usable payload, combined with a stronger, longer and lighter crane. Plus, more standard options are available to meet your service truck needs including headache rack, accessory mounting options, additional tail shelf options and more. PAL Pro 39 is manufactured with 12-gauge all A-60 galvaneal steel construction, a hybrid torsion box that eliminates frame and side pack deflection and the best rust protection in the industry.

NON-MARRING BOOM REST

Optional fixed or adjustable non-marring boom support E-coated black.



LINE-X ULTRA INTERIOR COMPARTMENT COATING FOR GREATER PROTECTION

LINE-X Ultra provides the ultimate protection for your compartment interiors. It resists the damage commonly caused by tools, chains and parts, and prevents the rust that comes as a result. As an added bonus, the coating is white in color and helps to brighten up the interior.

DOOR DESIGN ELIMINATE WELDING

Double panel doors with internal C-channel stiffeners, adhered with structural adhesive.

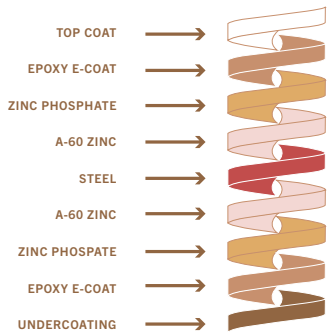

E-COAT CORROSION PROTECTION

PALFINGER's 12 step electrophoretic deposition dip process cleans the body and applies primer to the metal surfaces, ensuring complete coverage and automotive grade corrosion protection.

ALUMINUM DOORS & TRAYS LIGHT-WEIGHT & CORROSION RESISTANT

PALFINGER's unique automotive adhesive bonded two-piece doors, hinges, and compartment divider trays are now all in aluminum. This means increased payload capacity.

RAISED COMPARTMENT REINFORCEMENTS STRUCTURAL INTEGRITY

Every raised compartment comes with our engineered structural gussets to prevent against body cracking in the door corners.

FEATURES



HYBRID TORSION BOX BUILT FOR CRANES

Designed from the start for crane applications and utilizing 12ga A-60 galvanneal steel, the hybrid torsion box eliminates truck frame twist and side pack deflection.

STRUCTURAL CROSS-MEMBERS PAYLOAD SUPPORT

Tubular 3" x 5" structural steel cross-members interlace the torsion box to support compartment loads.

OUTRIGGER HOUSING INTEGRATED LIFTING SUPPORT

Integrated outrigger tube reduces stress on chassis frame by transferring the crane load directly to the ground.

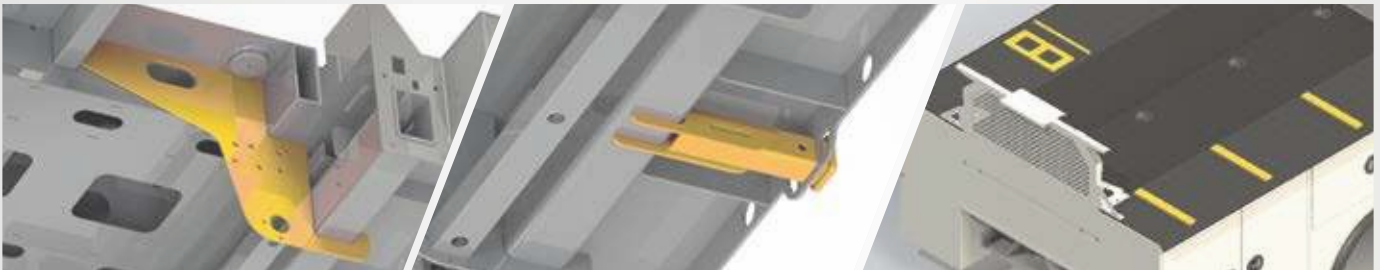

REAR SHEAR PLATE BODY MOUNTS SECURE AND SUPPORTIVE MOUNTING

Steel plates prevent lateral body shift on chassis, providing additional support for crane loads.

INTEGRATED HITCH RECEIVER CLASS 5 RECEIVER

2" I.D. receiver tube, attached directly to body structure. 16,000 lbs towing capacity.

THREADED WELDMENT OPTIONS TO PROTECT YOUR BODY

Boom rest, welder, compressor, EnPak, Air-n-Arc and AirPak mounts are available from the factory to eliminate the need to drill holes in the body.



WORK BENCH BUILT FOR YOUR HARD WORK

A true mechanics workbench, featuring 12" or 21" work bench bumpers, receiver hitch, 1/4" steel top plate and thru compartment for additional storage. (Pictured 21" pipe trough.)

HEADACHE RACK SAVES COSTLY REPAIRS

This light bar bracket with a punched screen prevents cargo area contents from making contact with the rear window of the cab - saving you from costly rear window repairs & cleanup.

BOLT ON HANDRAIL OPTION FOR ADDED SAFETY

Ergonomically designed handrail option, with a stable surface to grip, for your added security against tripping or slipping hazards.

STANDARD CONFIGURATIONS

39-9

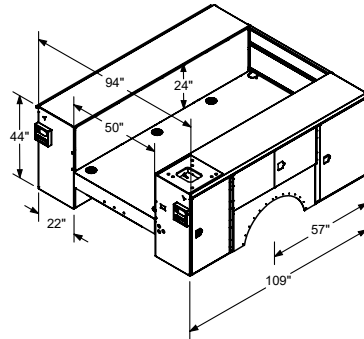

9' standard configuration
 44" tall compartment heights
 14" tall one handed tailgate
 Treadplate compartment top overlays

39-9CS

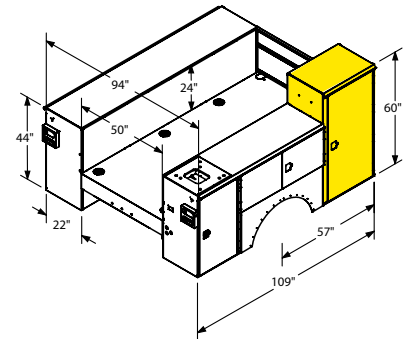

9' standard configuration
 44" tall compartment heights
 CS front compartment raised to 60"
 14" tall one handed tailgate
 Treadplate compartment top overlays
 Reinforced raised compartment

39-9SSCS

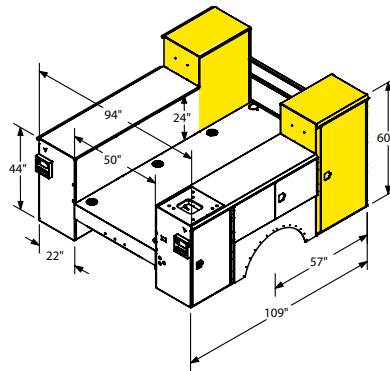

9' standard configuration
 44" tall compartment heights
 SS & CS front compartments raised to 60"
 14" tall one handed tailgate
 Treadplate compartment top overlays
 Reinforced raised compartments

39-11

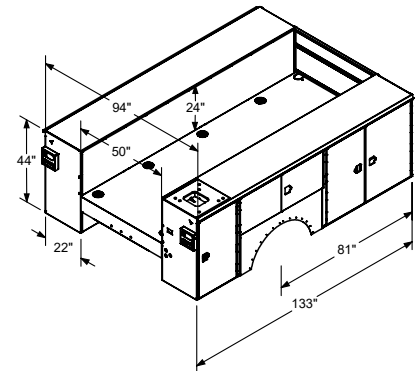

11' standard configuration
 44" tall compartment heights
 14" tall one handed tailgate
 Treadplate compartment top overlays

39-11CS

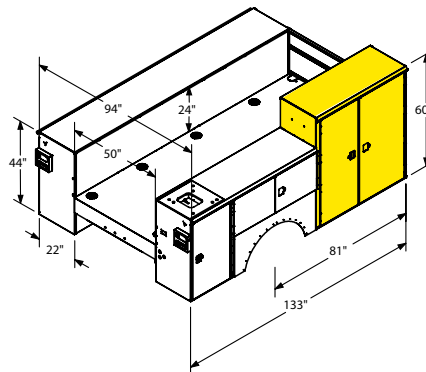

11' standard configuration
 44" tall compartment heights
 CS front compartments raised to 60"
 14" tall one handed tailgate
 Treadplate compartment top overlays
 Reinforced raised compartment

39-11SSCS

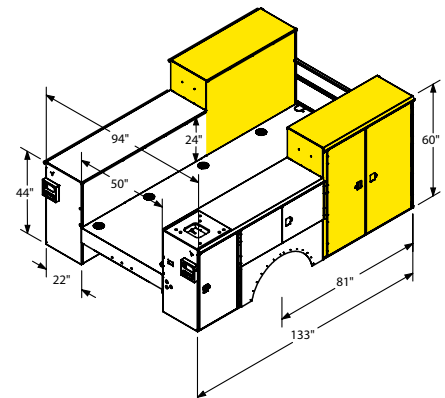

11' standard configuration
 44" tall compartment heights
 SS & CS front compartments raised to 60"
 14" tall one handed tailgate
 Treadplate compartment top overlays
 Reinforced raised compartments

SERVICE CRANE

PRODUCT RANGE

TECHNICAL SPECIFICATIONS

MODEL	CAPACITY	RATED LIFTING MOMENT	MAX LIFTING MOMENT	BOOM EXTENSIONS	BOOM LENGTH	WINCH SPEED	STANDARD WEIGHT	CHASSIS SPECIFICATION
PSC 3216 E	4,000 lbs. (1,814 kg)	12,500 ft*lbs. (17 kNm (1.7 mt))	14,560 ft*lbs. (19.6 kNm (2 mt))	1 Hydraulic + 1 Manual (2 Hydraulic Option)	16 ft. (4.9 m)	21.2 ft./min (6.46 m/min)	650 lbs. (295 kg)	Class 3
PSC 3216 H	4,000 lbs. (1,814 kg)	12,500 ft*lbs. (17 kNm (1.7 mt))	14,560 ft*lbs. (19.6 kNm (2 mt))	1 Hydraulic + 1 Manual (2 Hydraulic Option)	16 ft. (4.9 m)	29.7 ft./min (9.05 m/min)	630 lbs. (286 kg)	Class 3
PSC 4016 E	4,000 lbs. (1,814 kg)	18,500 ft*lbs. (25.1 kNm (2.6 mt))	23,235 ft*lbs. (31.4 kNm (3.2 mt))	1 Hydraulic + 1 Manual (2 Hydraulic Option)	16 ft. (4.9 m)	21.2 ft./min (6.46 m/min)	650 lbs. (295 kg)	Class 3
PSC 4016 H	4,000 lbs. (1,814 kg)	18,500 ft*lbs. (25.1 kNm (2.6 mt))	23,235 ft*lbs. (31.4 kNm (3.2 mt))	1 Hydraulic + 1 Manual (2 Hydraulic Option)	16 ft. (4.9 m)	29.7 ft./min (9.05 m/min)	630 lbs. (286 kg)	Class 3
PSC 4025 E	4,000 lbs. (1,814 kg)	18,500 ft*lbs. (25.1 kNm (2.6 mt))	20,585 ft*lbs. (27.9 kNm (2.9 mt))	2 Hydraulic	25 ft. (7.6 m)	21.2 ft./min (6.46 m/min)	1,010 lbs. (458 kg)	Class 3
PSC 4025 H	4,000 lbs. (1,814 kg)	18,500 ft*lbs. (25.1 kNm (2.6 mt))	20,585 ft*lbs. (27.9 kNm (2.9 mt))	2 Hydraulic	25 ft. (7.6 m)	29.7 ft./min (9.05 m/min)	995 lbs. (451 kg)	Class 3
PSC 5025 E	5,000 lbs. (2,268 kg)	32,500 ft*lbs. (44.2 kNm (4.5 mt))	36,360 ft*lbs. (49.3 kNm (5 mt))	2 Hydraulic	25 ft. (7.6 m)	18.8 ft./min (5.73 m/min)	1,170 lbs. (530 kg)	Class 4
PSC 5025 H	5,000 lbs. (2,268 kg)	32,500 ft*lbs. (44.2 kNm (4.5 mt))	36,360 ft*lbs. (49.3 kNm (5 mt))	2 Hydraulic	25 ft. (7.6 m)	56 ft./min (17.07 m/min)	1,155 lbs. (525 kg)	Class 4
PSC 6025 E	6,000 lbs. (2,750 kg)	38,500 ft*lbs. (52.2 kNm (5.3 mt))	42,800 ft*lbs. (58.0 kNm (5.9 mt))	2 Hydraulic	25 ft. (7.6 m)	43.3 ft./min (13.20 m/min)	1,280 lbs. (580 kg)	Class 4
PSC 6025 H	6,000 lbs. (2,750 kg)	38,500 ft*lbs. (52.2 kNm (5.3 mt))	42,800 ft*lbs. (58.0 kNm (5.9 mt))	2 Hydraulic	25 ft. (7.6 m)	51 ft./min (15.54 m/min)	1,230 lbs. (560 kg)	Class 4
PSC 8029 H	8,000 lbs. (3,650 kg)	43,000 ft*lbs. (58.3 kNm (5.9 mt))	49,180 ft*lbs. (66.5 kNm (6.8 mt))	2 Hydraulic	29 ft. (8.9 m)	60 ft./min (18.28 m/min)	2,149 lbs. (975 kg)	Class 5
PSC 10829 H	10,800 lbs. (4,900 kg)	62,000 ft*lbs. (84.1 kNm (8.6 mt))	68,900 ft*lbs. (93.2 kNm (9.5 mt))	2 Hydraulic	29 ft. (8.9 m)	60 ft./min (18.28 m/min)	2,407 lbs. (1,092 kg)	Class 6
PSC 12529 H	12,500 lbs. (5,700 kg)	72,000 ft*lbs. (97.6 kNm (10 mt))	79,450 ft*lbs. (107.7 kNm (11 mt))	2 Hydraulic	29 ft. (8.9 m)	60 ft./min (18.28 m/min)	2,731 lbs. (1,239 kg)	Class 6
PSC 14029 H	14,000 lbs. (6,400 kg)	86,000 ft*lbs. (116.6 kNm (11.9 mt))	94,676 ft*lbs. (128.4 kNm (13 mt))	2 Hydraulic	29 ft. (8.9 m)	60 ft./min (18.28 m/min)	2,833 lbs. (1,285 kg)	Class 7



OSP_PALPRO39_06/20

Cranes shown in the leaflet are partially optional equipped and do not always correspond to the standard version. All PSC models are subject to change as PALFINGER updates, improves, and technologically advances their cranes and the industry.

OMAHA STANDARD PALFINGER
 3501 S. 11th Street | Council Bluffs, IA
 51501-0876 | USA
 T + 1 800 279 2201
 info@palfingerna.com

PALFINGER.COM