

CH

MAN

## PK 12502 SH E-DRIVE TGM 18.320 4X2 BL CH

CONTRACT NUMBER: PALDRIVE 251

NEW

AVAILABLE



### OFFER INFORMATION

Location details

Lengau, 5211 - Austria 

Dealer Name

Palfinger EMEA GmbH AT

**PALFINGER**

Availability

Available

Product type

New

Contract number

Paldrive 251

Dealer E-mail

sales@palfinger.com

Dealer phone

004366488345792

### SPECIFICATION

**MAN + PK12502 SH eDrive +  
Palfinger Installation**

**Handover inbetween two weeks after official  
order.**

#### PK 12502 SH eDrive

- eDrive (100% electrically operable)
- Hydraulic 3-fold extension
- High-speed extension system with return oil recovery
- Swivel range 400°
- Hydraulic support leg extension (max.support width 4.900mm)
- Support leg extension 100mm
- Rigid support legs

Prior sale and changes reserved!

Print date: May 10, 2024, 7:38:50 PM

## CH

---

- Paltronic 40
- HPSC-E + LOAD
- Sanreco radio remote control (2-2-2) cross lever
- Painting RAL3020
- Working lights on the articulated arm
- Hose equipment for two additional devices including quick coupling (multi-faster)
- 8.0t load hook
- inclusive HPX-Grapple (350 Liter)

### **Tipper (MEILLER)**

- MEILLER type 9
- 4,000 x 2,420 mm
- 800 mm height of the front wall of the tipping bridge
- 600 mm high side wall tipping bridge, steel
- Floor tipping bridge, made of steel HB 400, 4 mm
- Lashing eyes in the floor panel
- Rear wall of the tipping bridge, swinging and can be folded down to a certain extent, manual claw lock

### **MAN**

- TGM 18.320 4x2 BL CH
- 320PS / 1.250Nm
- Leaf suspension 1st and 2nd axis
- Fuel tank 150l / AD-Blue 35l
- Tires 1st axle 315/80 R22.5
- Drive axle tires 315 / 80R22.5

PK 12502 SH e-Drive MAN TGM 18.320 4x2 BL



CH

---

- Cabin color: Traffic White RAL9016 / Chassis

color: Graphite Black RAL9011

- Electric and compressed air hanger supply

- RINGFEDER trailer coupling type 4040 / G150B

CH

**PRODUCT**

|                          |             |                                 |                 |
|--------------------------|-------------|---------------------------------|-----------------|
| <b>Manufacturer</b>      | Palfinger   | <b>Lifting moment</b>           | 11,4 mt         |
| <b>Model</b>             | PK 12502 SH | <b>Outreach / Lifting power</b> | 9,7m / 1.040 Kg |
| <b>Construction year</b> | 2022        | <b>Max outreach</b>             | 9,7 m           |

**TRUCK**

|                           |          |                             |                  |
|---------------------------|----------|-----------------------------|------------------|
| <b>Truck manufacturer</b> | MAN      | <b>Axes</b>                 | 4x2              |
| <b>Construction year</b>  | 2022     | <b>Gross vehicle weight</b> | 18.000 Kg        |
| <b>Drivers cabine</b>     | CC       | <b>Dead weight</b>          | 10.000 Kg        |
| <b>Wheel base</b>         | 3.900 mm | <b>Payload</b>              | 8.000 Kg         |
| <b>Power</b>              | 320 HP   | <b>Payload category</b>     | 6t - 15t         |
| <b>Emmission standard</b> | EURO 6e  | <b>Construction</b>         | Crane and tipper |

Subject to change, production tolerances have to be taken into account.

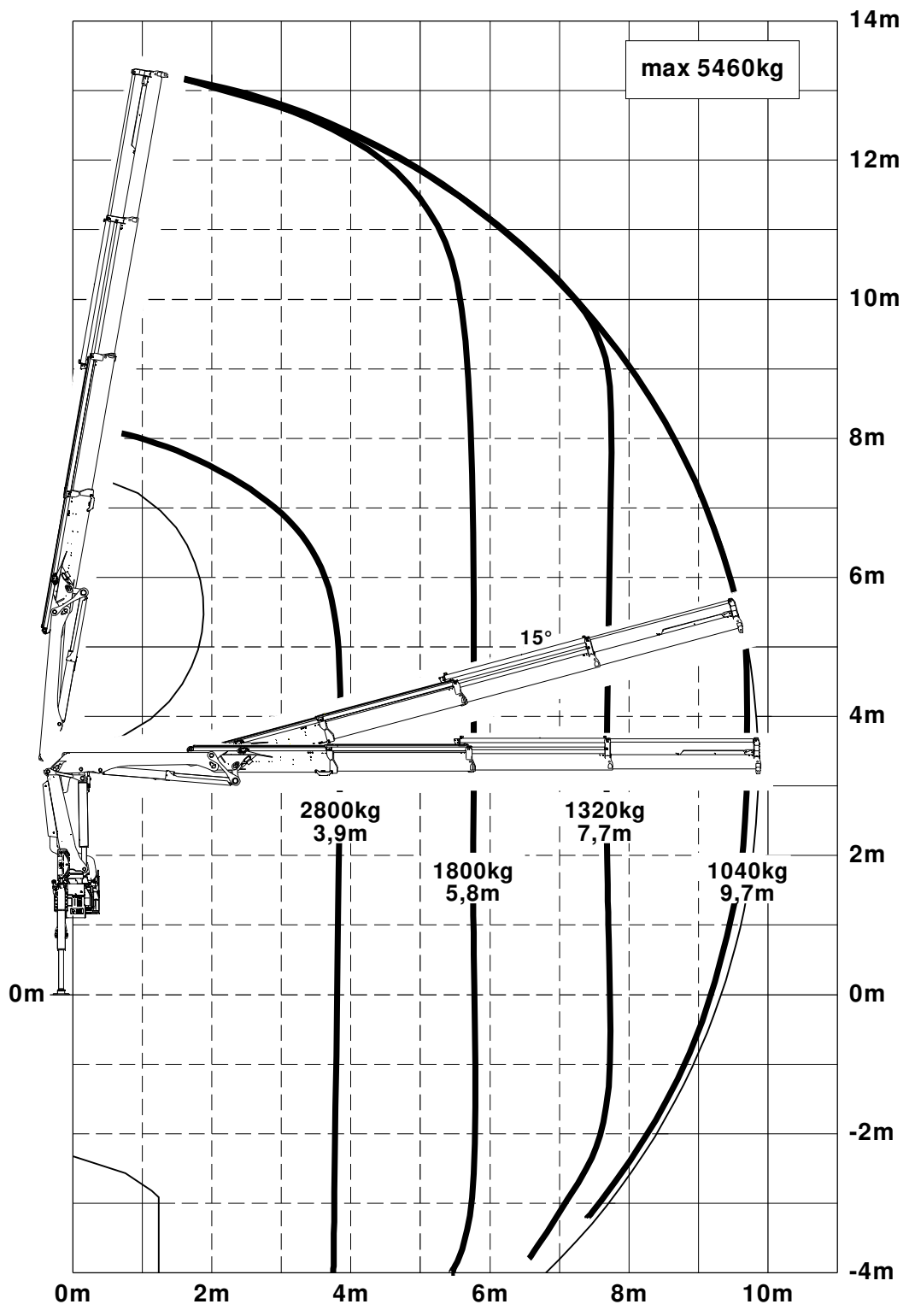

Symbolic crane figure, indications at 20° main boom position & load arm in horizontal position



For Rope winch load capacity refer to page  
Page 020.21200



**PK 10002 SH | PK 12502 SH**

# **LOADS CAN BE MOVED MORE PRECISELY DUE TO THE STANDARD SOFT STOP**

**LIFETIME EXCELLENCE**



# LIFETIME EXCELLENCE

PALFINGER loader cranes are convincing due to their superior life-cycle performance. They are the most economical and also the most reliable over the entire product life. From solution finding to resale.

- **Better solutions**
- **Better efficiency**
- **Better ergonomics**
- **Higher availability**
- **More reliability**
- **Better ecology**
- **Higher serviceability**
- **Higher value retention**





# FAST AND EFFICIENT

- Maximum precision and safety due to optional AOS
- High value retention due to coating technology
- More lifting power due to S-HPLS
- Additional applications with Power Link Plus
- Increased comfort and safety due to Soft Stop





# FIRST-RATE IN DESIGN AND PERFORMANCE

## 12 Highlights



### Power Link Plus

High variety of uses

With the 15-degree reverse linkage system, you can reach through low door openings and also work inside buildings. Heavy crane work – even in difficult conditions.



### Low-maintenance extension system

Reduces service time

With sliding elements made of synthetic material and the high-quality KTL coating, this boom system significantly simplifies service performed by the operator. This saves time and money – and protects the environment.



### High Speed Extension

For efficient assignments

The High Speed Extension speeds up the extension boom system. Crane works faster and more efficiently.

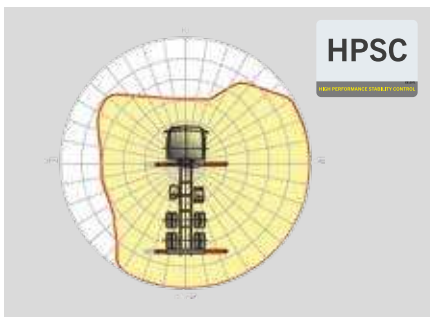

### HPSC

Maximum utilisation of the working range

The variable stabiliser positioning of the High Performance Stability Control System makes it possible to utilise the lifting capacity to the maximum. It enables working within tight spaces.



### S-HPLS

More lifting power when it counts

S-HPLS is one of the most important functions of the PALTRONIC 150. It is a fully automatic system for increasing lifting power. The lifting power and crane speed can be continuously adapted to suit requirements.



### PALcom P7

Communication with the operator

The new PALcom P7 features a modern, ergonomic design. The centrally located knob „PALdrive“ and a large colour display enables easy and safe operation.



### Hose equipment for attachments

Versatile and user-friendly

The hose equipment offers an easy means of connecting auxiliary equipment. The hose equipment is guided in hose trays for protection.



### Functional design

Practical and attractive

Robust plastic covers protect crane parts against dirt and damage. Better appearance and increased operational comfort – during the entire lifetime.



### Coating technology

Top quality surface protection at a glance

The KTL coating lays the foundation for a perfect surface protection. Afterwards the components are either coated in the powder-coating facility or are finished with a two-components-topcoat. High value retention and excellent corrosion protection for the whole life of a crane.

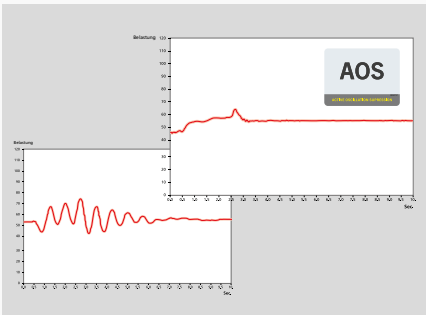

### AOS

Maximum precision and safety

The active oscillation suppression system prevents “post-oscillation” in the event of rapid braking or load changes. The stress peaks on the extension boom system are reduced and material fatigue and wear are minimised. This increases the resale value.



### Lighting package

More crane safety particularly at dusk and dark

LEDs which backlight the control panel make it easier to read off the crane functions and provide the crane operator with a quick overview of the entire panel during the working process. LED warning lights in the supporting cylinders mean greater safety for crane operator and passers-by.

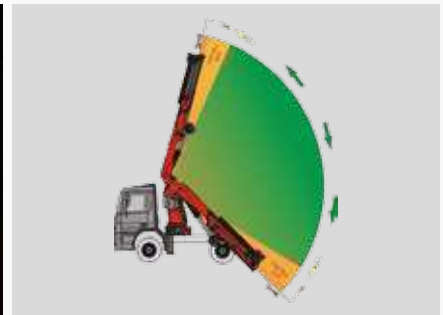

### Soft Stop function

Improved comfort and safety

The Soft Stop function is an electronic limit position damper. It causes gentle braking of all crane movements before the limit position is reached. Hence, jerky movements and load impacts can be avoided. The crane can be operated more gently and precisely.



\* Optional features / country-specific equipment

PK 10002 SH

# HIGH PERFORMANCE

Innovative technology.

STD

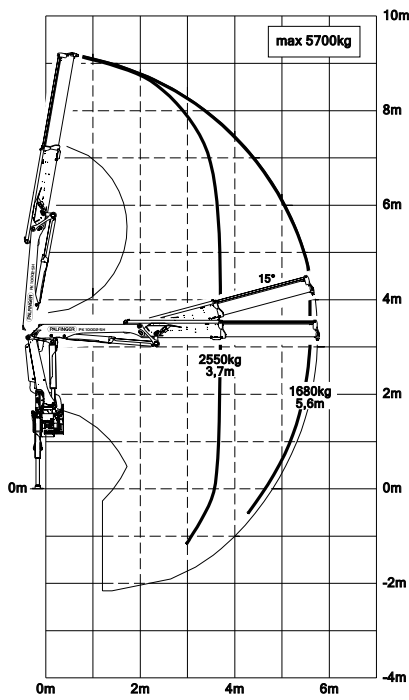

A

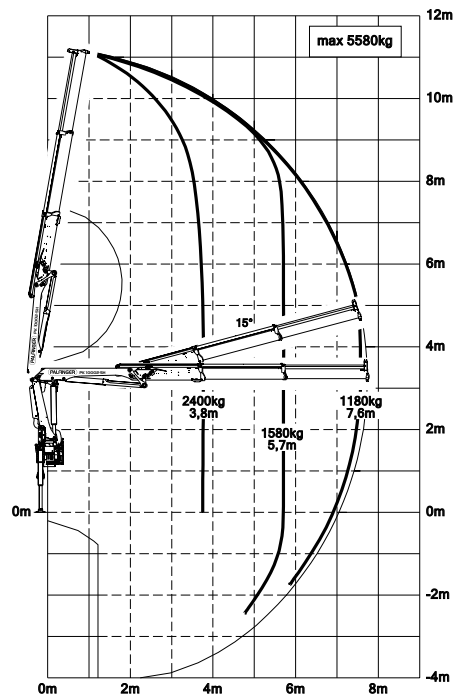

C

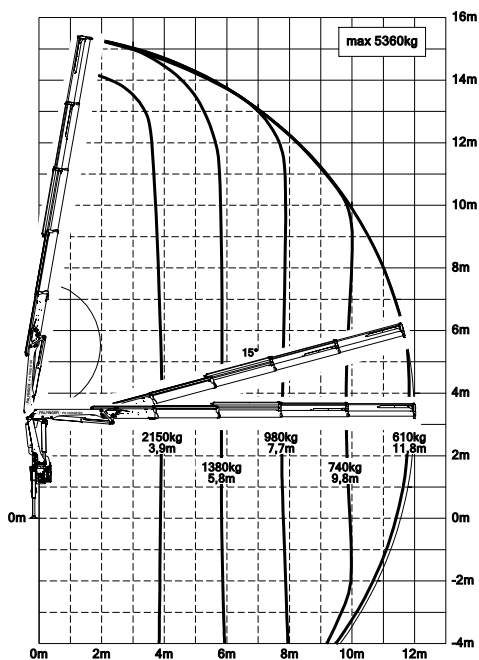

D

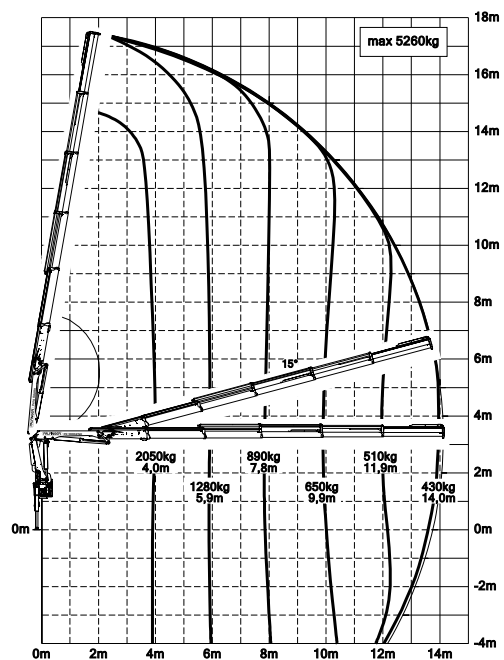

The outreaches stated are with a boom angle of 20° and are therefore not the maximum.

## Lifting capacities

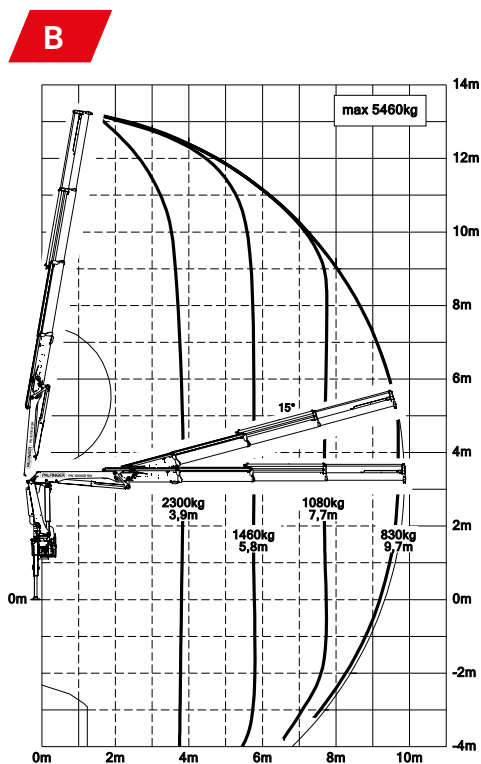

| max.  |        | 5700 kg | 55.9 kN  | STD |
|-------|--------|---------|----------|-----|
| 3.7 m | 12' 2" | 2550 kg | 5600 lbs |     |
| 5.6 m | 18' 4" | 1680 kg | 3700 lbs |     |

| max.  |         | 5580 kg | 54.7 kN  | A |
|-------|---------|---------|----------|---|
| 3.8 m | 12' 6"  | 2400 kg | 5300 lbs |   |
| 5.7 m | 18' 8"  | 1580 kg | 3450 lbs |   |
| 7.6 m | 24' 11" | 1180 kg | 2600 lbs |   |

| max.    |         | 5460 kg | 53.6 kN  | B |
|---------|---------|---------|----------|---|
| 3.9 m   | 12' 10" | 2300 kg | 5000 lbs |   |
| 5.8 m   | 19' 0"  | 1460 kg | 3250 lbs |   |
| 7.7 m   | 25' 3"  | 1080 kg | 2350 lbs |   |
| 9.7 m   | 31' 10" | 830 kg  | 1840 lbs |   |
| 11.9 m* | 39' 1"  | 640 kg  | 1410 lbs |   |
| 13.9 m* | 45' 7"  | 520 kg  | 1140 lbs |   |

| max.    |         | 5360 kg | 52.6 kN  | C |
|---------|---------|---------|----------|---|
| 3.9 m   | 12' 10" | 2150 kg | 4750 lbs |   |
| 5.8 m   | 19' 0"  | 1380 kg | 3050 lbs |   |
| 7.7 m   | 25' 3"  | 980 kg  | 2150 lbs |   |
| 9.8 m   | 32' 2"  | 740 kg  | 1640 lbs |   |
| 11.8 m  | 38' 9"  | 610 kg  | 1340 lbs |   |
| 13.8 m* | 45' 3"  | 490 kg  | 1080 lbs |   |
| 15.8 m* | 51' 10" | 380 kg  | 840 lbs  |   |

| max.    |        | 5260 kg | 51.6 kN  | D |
|---------|--------|---------|----------|---|
| 4.0 m   | 13' 1" | 2050 kg | 4550 lbs |   |
| 5.9 m   | 19' 4" | 1280 kg | 2800 lbs |   |
| 7.8 m   | 25' 7" | 890 kg  | 1960 lbs |   |
| 9.9 m   | 32' 6" | 650 kg  | 1440 lbs |   |
| 11.9 m  | 39' 1" | 510 kg  | 1140 lbs |   |
| 14.0 m  | 45' 9" | 430 kg  | 940 lbs  |   |
| 16.0 m* | 52' 6" | 350 kg  | 770 lbs  |   |

\*mechanical extension

# PERFECT DIMENSIONS

## EXTENSION BOOM VARIATIONS

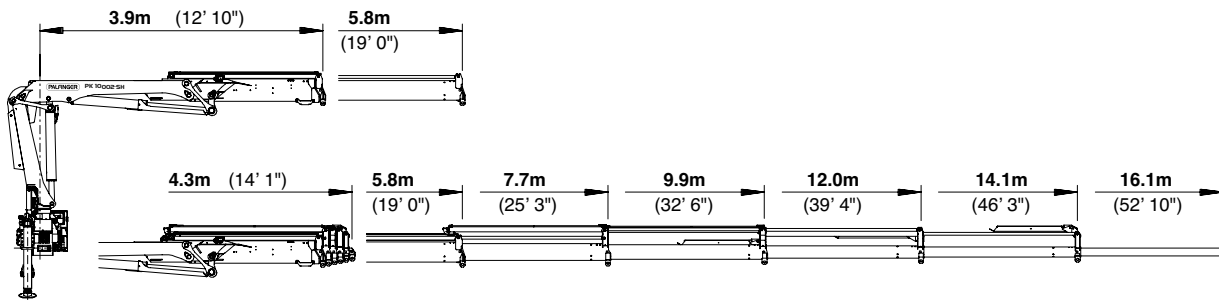

## DIMENSIONS

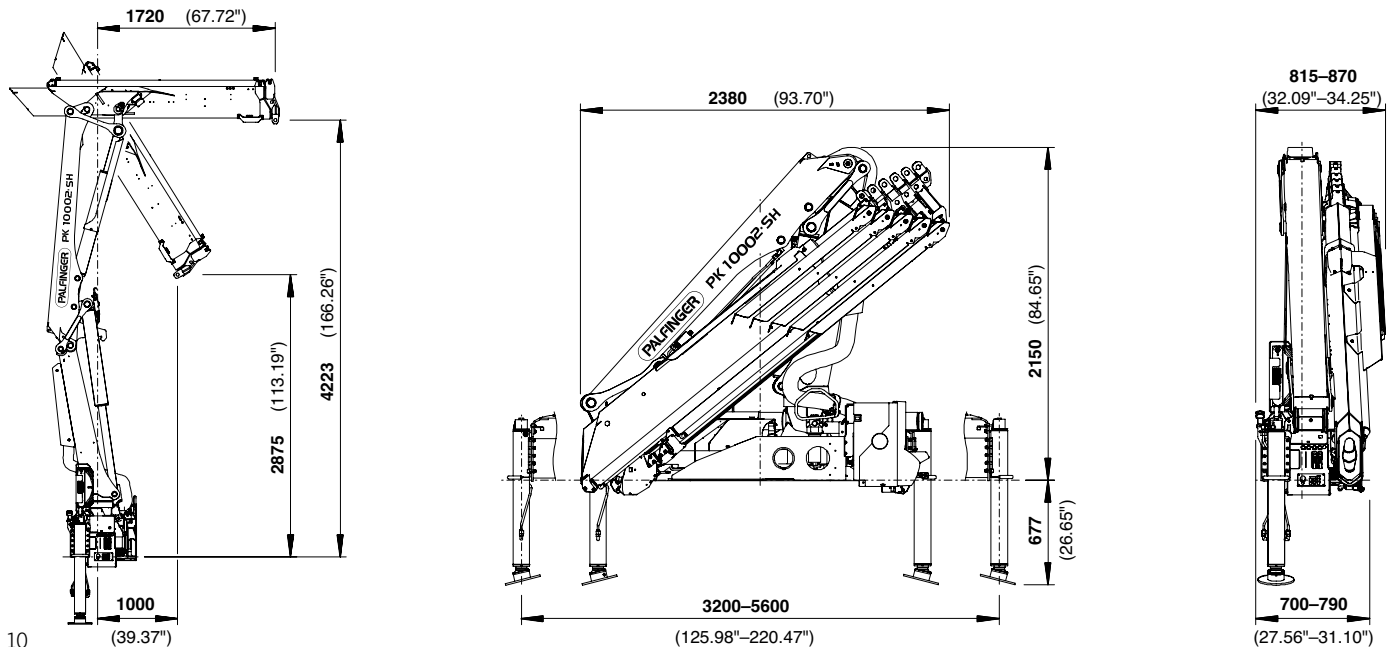





## Technical specifications

### EN 12999 HC1 HD5/B3



#### PK 10002 SH

|                               |                              |                                      |
|-------------------------------|------------------------------|--------------------------------------|
| Max. lifting moment           | 9.4 mt/91.9 kNm              | 67780 ft.lbs                         |
| Max. lifting capacity         | 5700 kg/55.9 kN              | 12570 lbs                            |
| Max. hydraulic outreach       | 14.1 m                       | 46' 3"                               |
| Max. manual outreach          | 16.1 m                       | 52' 10"                              |
| Slewing angle                 | 400°                         |                                      |
| Slewing torque                | 1.0 mt/9.8 kNm               | 7230 ft.lbs                          |
| Stabiliser spread (std./max.) | 3.2 m / 5.6 m                | 10' 6" / 18' 4"                      |
| Fitting space required (std.) | 0.70 m                       | 2' 4"                                |
| Width folded                  | 2.38 m                       | 7' 10"                               |
| Max. operating pressure       | 365 bar                      | 5293 psi                             |
| Recommended pump capacity     | from 40 l/min<br>to 50 l/min | 10.6 US gal./min<br>13.2 US gal./min |
| Dead weight (std.)            | 1070 kg                      | 2359 lbs                             |

PK 12502 SH

# HIGH PERFORMANCE

Proven in continuous situations.

STD

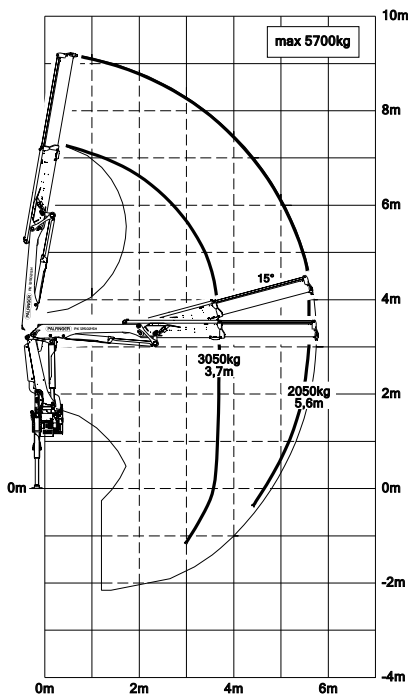

A

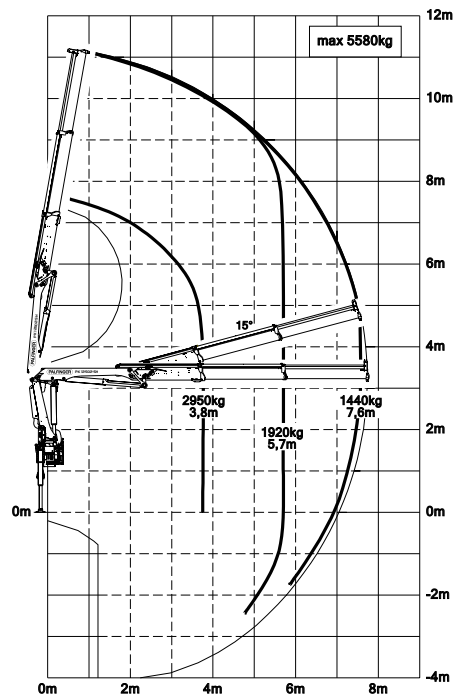

C

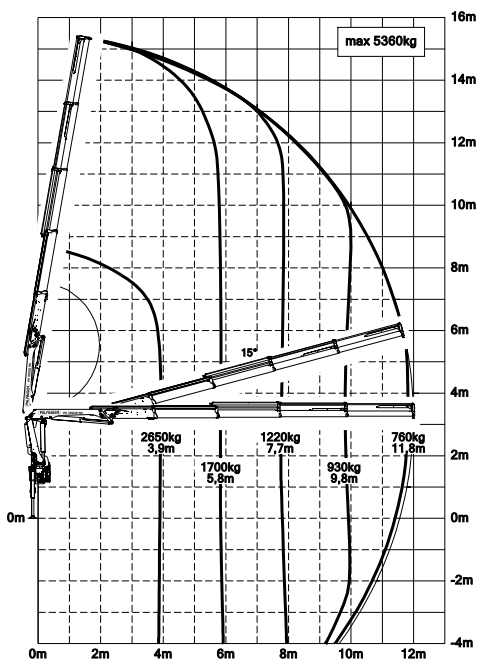

D

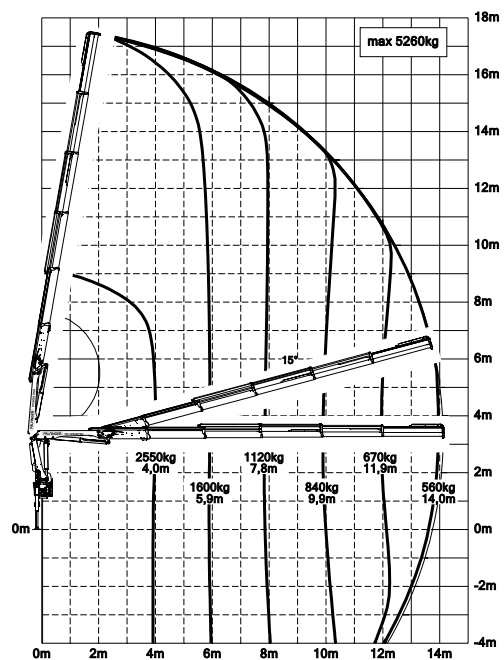

The outreaches stated are with a boom angle of 20° and are therefore not the maximum.

## Lifting capacities

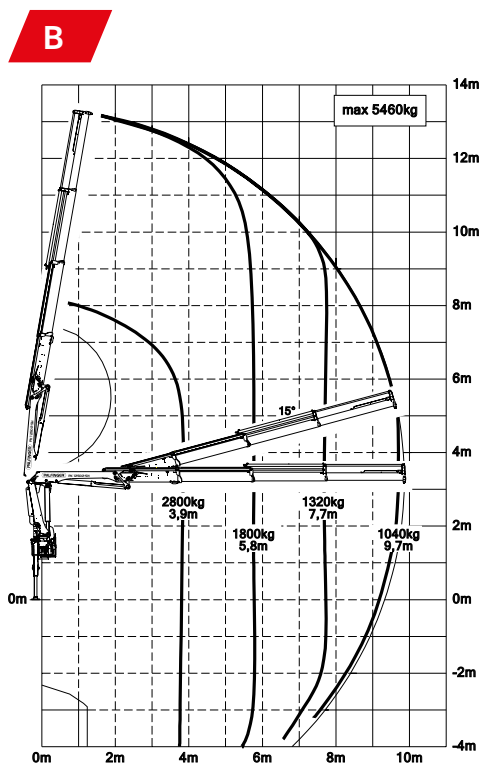

| max.  |        | <b>5700 kg</b> | <b>55.9 kN</b> | <b>STD</b> |
|-------|--------|----------------|----------------|------------|
| 3.7 m | 12' 2" | 3050 kg        | 6800 lbs       |            |
| 5.6 m | 18' 4" | 2050 kg        | 4500 lbs       |            |

| max.  |         | <b>5580 kg</b> | <b>54.7 kN</b> | <b>A</b> |
|-------|---------|----------------|----------------|----------|
| 3.8 m | 12' 6"  | 2950 kg        | 6500 lbs       |          |
| 5.7 m | 18' 8"  | 1920 kg        | 4250 lbs       |          |
| 7.6 m | 24' 11" | 1440 kg        | 3150 lbs       |          |

| max.    |         | <b>5460 kg</b> | <b>53.6 kN</b> | <b>B</b> |
|---------|---------|----------------|----------------|----------|
| 3.9 m   | 12' 10" | 2800 kg        | 6200 lbs       |          |
| 5.8 m   | 19' 0"  | 1800 kg        | 4000 lbs       |          |
| 7.7 m   | 25' 3"  | 1320 kg        | 2900 lbs       |          |
| 9.7 m   | 31' 10" | 1040 kg        | 2300 lbs       |          |
| 11.9 m* | 39' 1"  | 800 kg         | 1760 lbs       |          |
| 13.9 m* | 45' 7"  | 660 kg         | 1460 lbs       |          |

| max.    |         | <b>5360 kg</b> | <b>52.6 kN</b> | <b>C</b> |
|---------|---------|----------------|----------------|----------|
| 3.9 m   | 12' 10" | 2650 kg        | 5900 lbs       |          |
| 5.8 m   | 19' 0"  | 1700 kg        | 3750 lbs       |          |
| 7.7 m   | 25' 3"  | 1220 kg        | 2700 lbs       |          |
| 9.8 m   | 32' 2"  | 930 kg         | 2050 lbs       |          |
| 11.8 m  | 38' 9"  | 760 kg         | 1680 lbs       |          |
| 13.8 m* | 45' 3"  | 620 kg         | 1380 lbs       |          |
| 15.8 m* | 51' 10" | 380 kg         | 840 lbs        |          |

| max.    |        | <b>5260 kg</b> | <b>51.6 kN</b> | <b>D</b> |
|---------|--------|----------------|----------------|----------|
| 4.0 m   | 13' 1" | 2550 kg        | 5600 lbs       |          |
| 5.9 m   | 19' 4" | 1600 kg        | 3550 lbs       |          |
| 7.8 m   | 25' 7" | 1120 kg        | 2500 lbs       |          |
| 9.9 m   | 32' 6" | 840 kg         | 1840 lbs       |          |
| 11.9 m  | 39' 1" | 670 kg         | 1480 lbs       |          |
| 14.0 m  | 45' 9" | 560 kg         | 1240 lbs       |          |
| 16.0 m* | 52' 6" | 380 kg         | 840 lbs        |          |

# PERFECT DIMENSIONS

## EXTENSION BOOM VARIATIONS

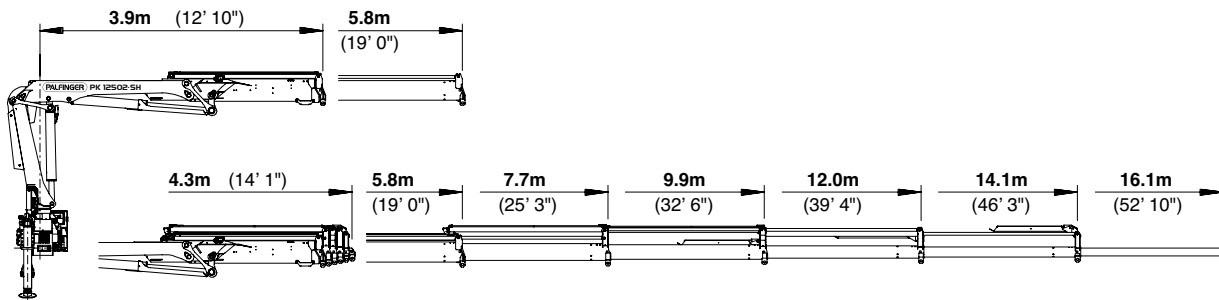

## DIMENSIONS

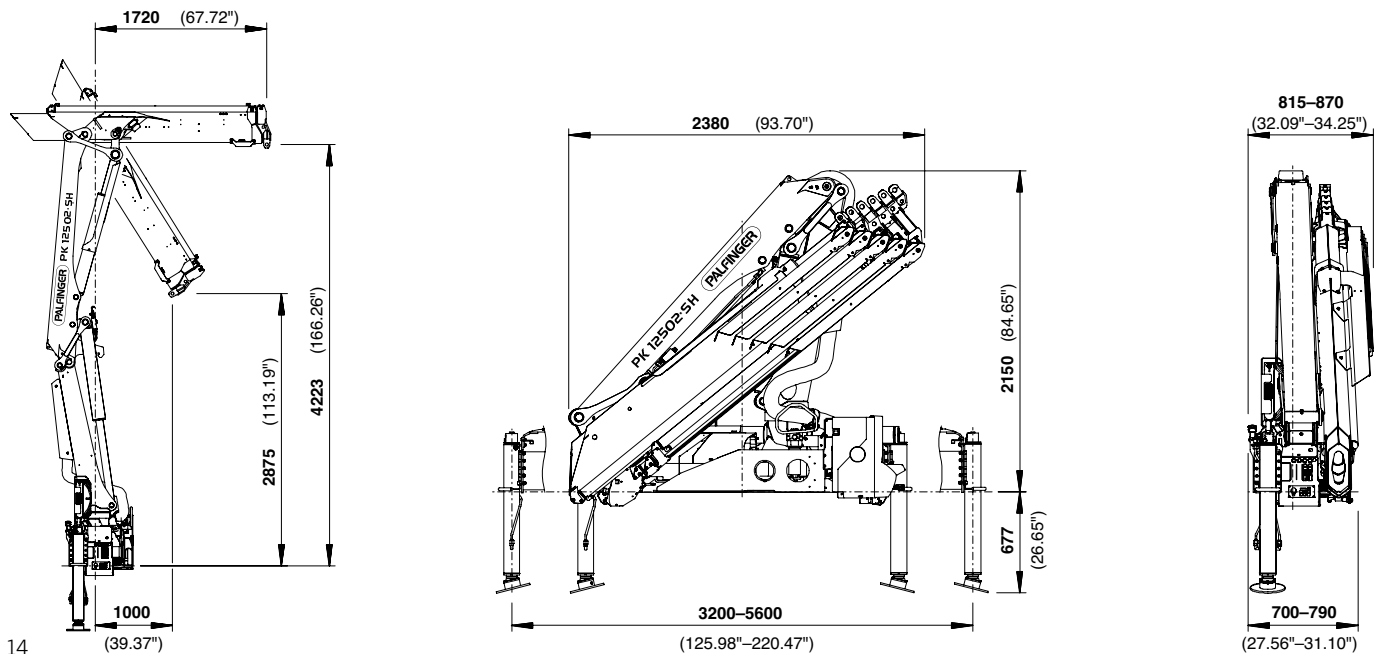

## Technical specifications

### EN 12999 HC1 HD5/B3

#### PK 12502 SH

|                               |                              |                                      |
|-------------------------------|------------------------------|--------------------------------------|
| Max. lifting moment           | 11.4 mt/112.0 kNm            | 82600 ft.lbs                         |
| Max. lifting capacity         | 5700 kg/55.9 kN              | 12570 lbs                            |
| Max. hydraulic outreach       | 14.1 m                       | 46' 3"                               |
| Max. manual outreach          | 16.1 m                       | 52' 10"                              |
| Slewing angle                 | 400°                         |                                      |
| Slewing torque                | 1.3 mt/12.7 kNm              | 9370 ft.lbs                          |
| Stabiliser spread (std./max.) | 3.2 m / 5.6 m                | 10' 6" / 18' 4"                      |
| Fitting space required (std.) | 0.70 m                       | 2' 4"                                |
| Width folded                  | 2.38 m                       | 7' 10"                               |
| Max. operating pressure       | 365 bar                      | 5293 psi                             |
| Recommended pump capacity     | from 45 l/min<br>to 60 l/min | 11.9 US gal./min<br>15.9 US gal./min |
| Dead weight (std.)            | 1160 kg                      | 2557 lbs                             |



KP-H10/12502SM2+EN

Cranes shown in the leaflet are partially optional equipped and do not always correspond to the standard version. Country-specific regulations must be observed. Dimensions may vary. Subject to technical changes, errors and translation mistakes.