

CH

MAN

PK 12502 SH E-DRIVE TGM 18.320 4X2 BL CH

CONTRACT NUMBER: PALDRIVE 251

NEW

AVAILABLE



OFFER INFORMATION

Location details

Lengau, 5211 - Austria 

Dealer Name

Palfinger EMEA GmbH AT

PALFINGER

Availability

Available

Available from

01.01.2019

Product type

New

Contract number

Paldrive 251

Dealer E-mail

sales@palfinger.com

Dealer phone

004366488345792

SPECIFICATION

**MAN + PK12502 SH eDrive +
Palfinger Installation**

**Handover inbetween two weeks after official
order.**

PK 12502 SH eDrive

- eDrive (100% electrically operable)
- Hydraulic 3-fold extension
- High-speed extension system with return oil recovery
- Swivel range 400°
- Hydraulic support leg extension (max.support width 4.900mm)
- Support leg extension 100mm
- Rigid support legs

Prior sale and changes reserved!

Print date: Apr 17, 2024, 7:09:18 PM

CH

- Paltronic 40
- HPSC-E + LOAD
- Sanreco radio remote control (2-2-2) cross lever
- Painting RAL3020
- Working lights on the articulated arm
- Hose equipment for two additional devices including quick coupling (multi-faster)
- 8.0t load hook
- inclusive HPX-Grapple (350 Liter)

Tipper (MEILLER)

- MEILLER type 9
- 4,000 x 2,420 mm
- 800 mm height of the front wall of the tipping bridge
- 600 mm high side wall tipping bridge, steel
- Floor tipping bridge, made of steel HB 400, 4 mm
- Lashing eyes in the floor panel
- Rear wall of the tipping bridge, swinging and can be folded down to a certain extent, manual claw lock

MAN

- TGM 18.320 4x2 BL CH
- 320PS / 1.250Nm
- Leaf suspension 1st and 2nd axis
- Fuel tank 150l / AD-Blue 35l
- Tires 1st axle 315/80 R22.5
- Drive axle tires 315 / 80R22.5

PK 12502 SH e-Drive MAN TGM 18.320 4x2 BL



CH

- Cabin color: Traffic White RAL9016 / Chassis

color: Graphite Black RAL9011

- Electric and compressed air hanger supply

- RINGFEDER trailer coupling type 4040 / G150B

CH

PRODUCT

Manufacturer	Palfinger	Lifting moment	11,4 mt
Model	PK 12.502 SH	Outreach / Lifting power	9,7m / 1.040 Kg
Construction year	2022	Max outreach	9,7 m

TRUCK

Truck manufacturer	MAN	Axes	4x2
Construction year	2022	Gross vehicle weight	18.000 Kg
Drivers cabine	CC	Dead weight	10.000 Kg
Wheel base	3.900 mm	Payload	8.000 Kg
Power	320 HP	Payload category	6t - 15t
Emmission standard	EURO 6e	Construction	Crane and tipper

Subject to change, production tolerances have to be taken into account.

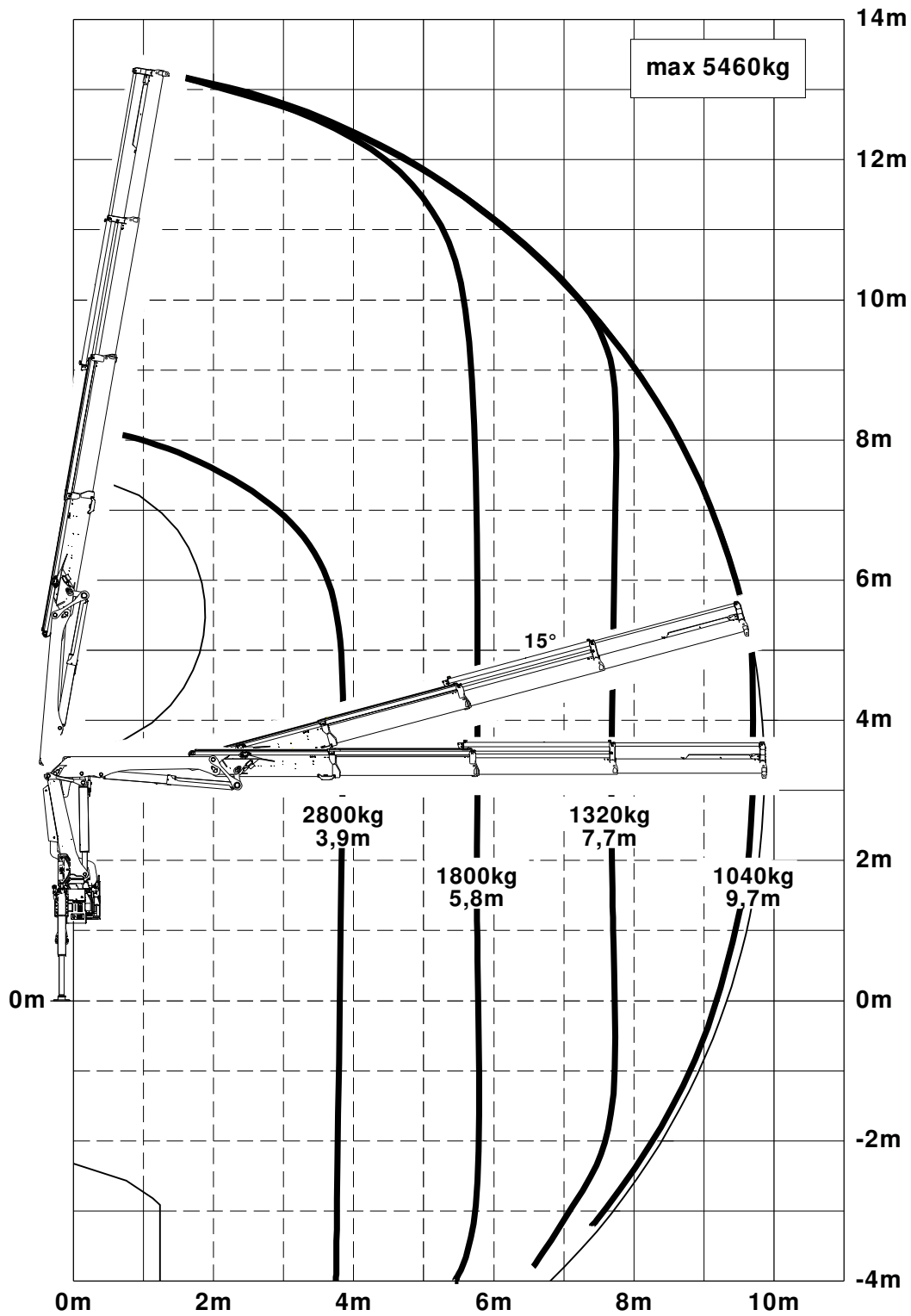

Symbolic crane figure, indications at 20° main boom position & load arm in horizontal position



For Rope winch load capacity refer to page
Page 020.21200

PK 10002 SH | PK 12502 SH

LOADS CAN BE MOVED MORE PRECISELY DUE TO THE STANDARD SOFT STOP

LIFETIME EXCELLENCE



LIFETIME EXCELLENCE

PALFINGER loader cranes are convincing due to their superior life-cycle performance. They are the most economical and also the most reliable over the entire product life. From solution finding to resale.

- **Better solutions**
- **Better efficiency**
- **Better ergonomics**
- **Higher availability**
- **More reliability**
- **Better ecology**
- **Higher serviceability**
- **Higher value retention**



FAST AND EFFICIENT

- Maximum precision and safety due to optional AOS
- High value retention due to coating technology
- More lifting power due to S-HPLS
- Additional applications with Power Link Plus
- Increased comfort and safety due to Soft Stop





FIRST-RATE IN DESIGN AND PERFORMANCE

12 Highlights



Power Link Plus

High variety of uses

With the 15-degree reverse linkage system, you can reach through low door openings and also work inside buildings. Heavy crane work – even in difficult conditions.



Low-maintenance extension system

Reduces service time

With sliding elements made of synthetic material and the high-quality KTL coating, this boom system significantly simplifies service performed by the operator. This saves time and money – and protects the environment.



High Speed Extension

For efficient assignments

The High Speed Extension speeds up the extension boom system. Crane works faster and more efficiently.

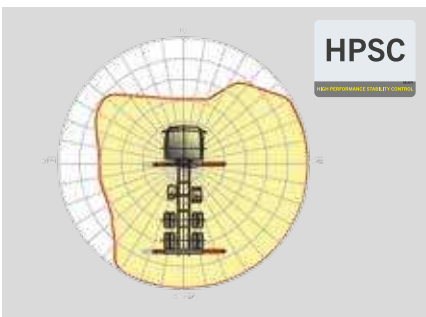

HPSC

Maximum utilisation of the working range

The variable stabiliser positioning of the High Performance Stability Control System makes it possible to utilise the lifting capacity to the maximum. It enables working within tight spaces.



S-HPLS

More lifting power when it counts

S-HPLS is one of the most important functions of the PALTRONIC 150. It is a fully automatic system for increasing lifting power. The lifting power and crane speed can be continuously adapted to suit requirements.



PALcom P7

Communication with the operator

The new PALcom P7 features a modern, ergonomic design. The centrally located knob „PALdrive“ and a large colour display enables easy and safe operation.



Hose equipment for attachments

Versatile and user-friendly

The hose equipment offers an easy means of connecting auxiliary equipment. The hose equipment is guided in hose trays for protection.



Functional design

Practical and attractive

Robust plastic covers protect crane parts against dirt and damage. Better appearance and increased operational comfort – during the entire lifetime.



Coating technology

Top quality surface protection at a glance

The KTL coating lays the foundation for a perfect surface protection. Afterwards the components are either coated in the powder-coating facility or are finished with a two-components-topcoat. High value retention and excellent corrosion protection for the whole life of a crane.

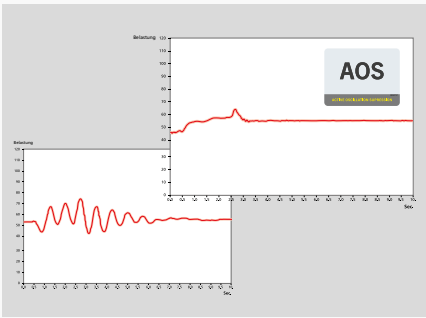

AOS

Maximum precision and safety

The active oscillation suppression system prevents “post-oscillation” in the event of rapid braking or load changes. The stress peaks on the extension boom system are reduced and material fatigue and wear are minimised. This increases the resale value.



Lighting package

More crane safety particularly at dusk and dark

LEDs which backlight the control panel make it easier to read off the crane functions and provide the crane operator with a quick overview of the entire panel during the working process. LED warning lights in the supporting cylinders mean greater safety for crane operator and passers-by.

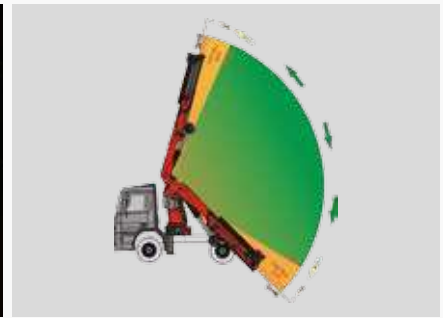

Soft Stop function

Improved comfort and safety

The Soft Stop function is an electronic limit position damper. It causes gentle braking of all crane movements before the limit position is reached. Hence, jerky movements and load impacts can be avoided. The crane can be operated more gently and precisely.



* Optional features / country-specific equipment

PK 10002 SH

HIGH PERFORMANCE

Innovative technology.

STD

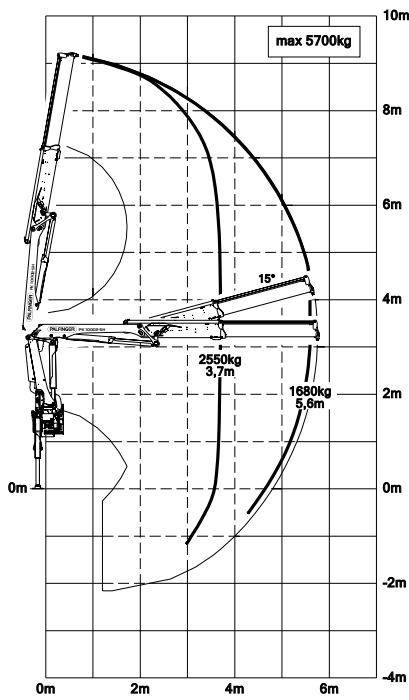

A

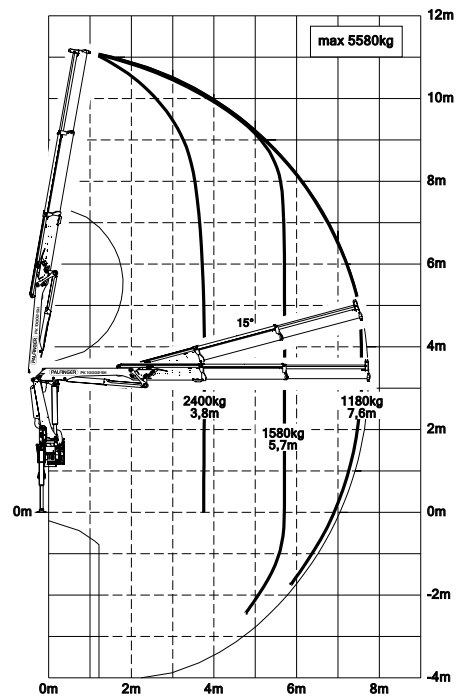

C

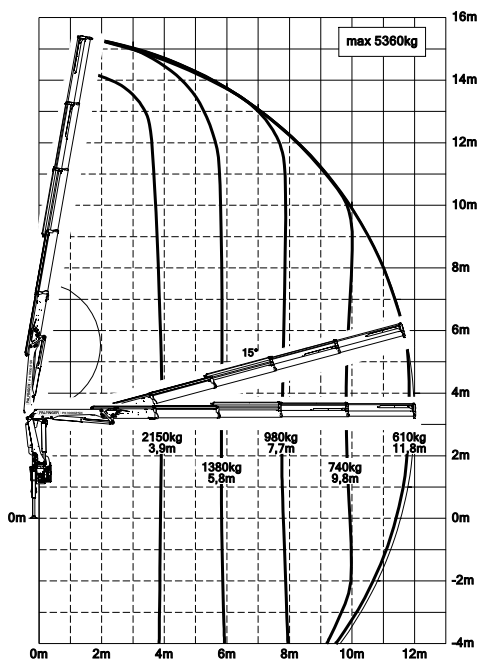

D

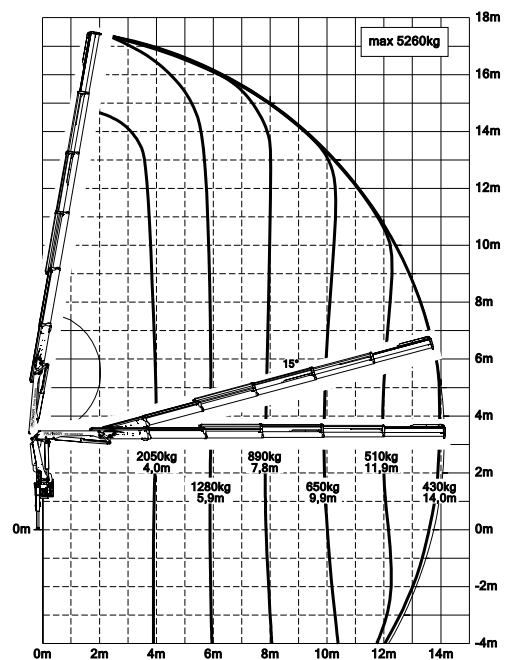

The outreaches stated are with a boom angle of 20° and are therefore not the maximum.

Lifting capacities

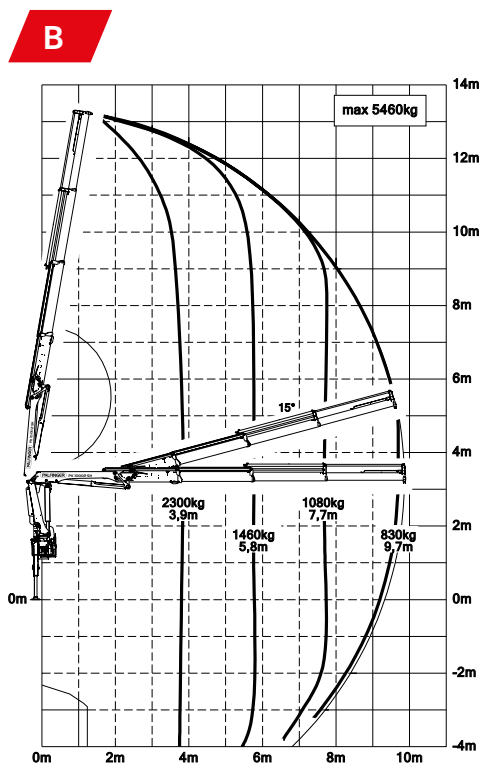

max.		5700 kg	55.9 kN	STD
3.7 m	12' 2"	2550 kg	5600 lbs	
5.6 m	18' 4"	1680 kg	3700 lbs	

max.		5580 kg	54.7 kN	A
3.8 m	12' 6"	2400 kg	5300 lbs	
5.7 m	18' 8"	1580 kg	3450 lbs	
7.6 m	24' 11"	1180 kg	2600 lbs	

max.		5460 kg	53.6 kN	B
3.9 m	12' 10"	2300 kg	5000 lbs	
5.8 m	19' 0"	1460 kg	3250 lbs	
7.7 m	25' 3"	1080 kg	2350 lbs	
9.7 m	31' 10"	830 kg	1840 lbs	
11.9 m*	39' 1"	640 kg	1410 lbs	
13.9 m*	45' 7"	520 kg	1140 lbs	

max.		5360 kg	52.6 kN	C
3.9 m	12' 10"	2150 kg	4750 lbs	
5.8 m	19' 0"	1380 kg	3050 lbs	
7.7 m	25' 3"	980 kg	2150 lbs	
9.8 m	32' 2"	740 kg	1640 lbs	
11.8 m	38' 9"	610 kg	1340 lbs	
13.8 m*	45' 3"	490 kg	1080 lbs	
15.8 m*	51' 10"	380 kg	840 lbs	

max.		5260 kg	51.6 kN	D
4.0 m	13' 1"	2050 kg	4550 lbs	
5.9 m	19' 4"	1280 kg	2800 lbs	
7.8 m	25' 7"	890 kg	1960 lbs	
9.9 m	32' 6"	650 kg	1440 lbs	
11.9 m	39' 1"	510 kg	1140 lbs	
14.0 m	45' 9"	430 kg	940 lbs	
16.0 m*	52' 6"	350 kg	770 lbs	

*mechanical extension

PERFECT DIMENSIONS

EXTENSION BOOM VARIATIONS

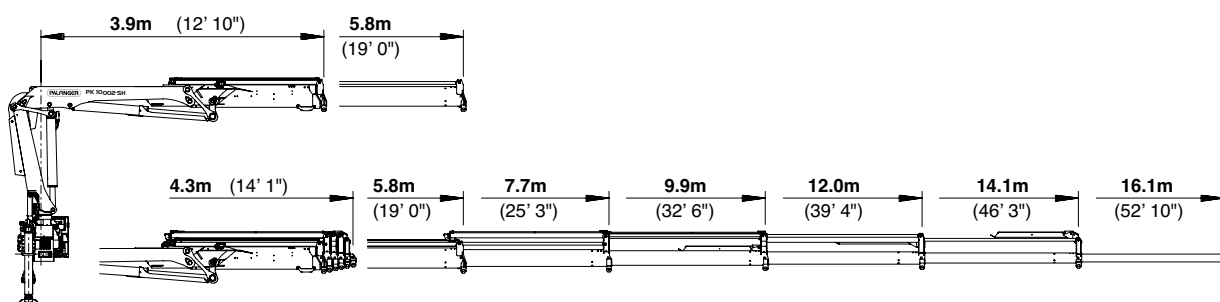

DIMENSIONS

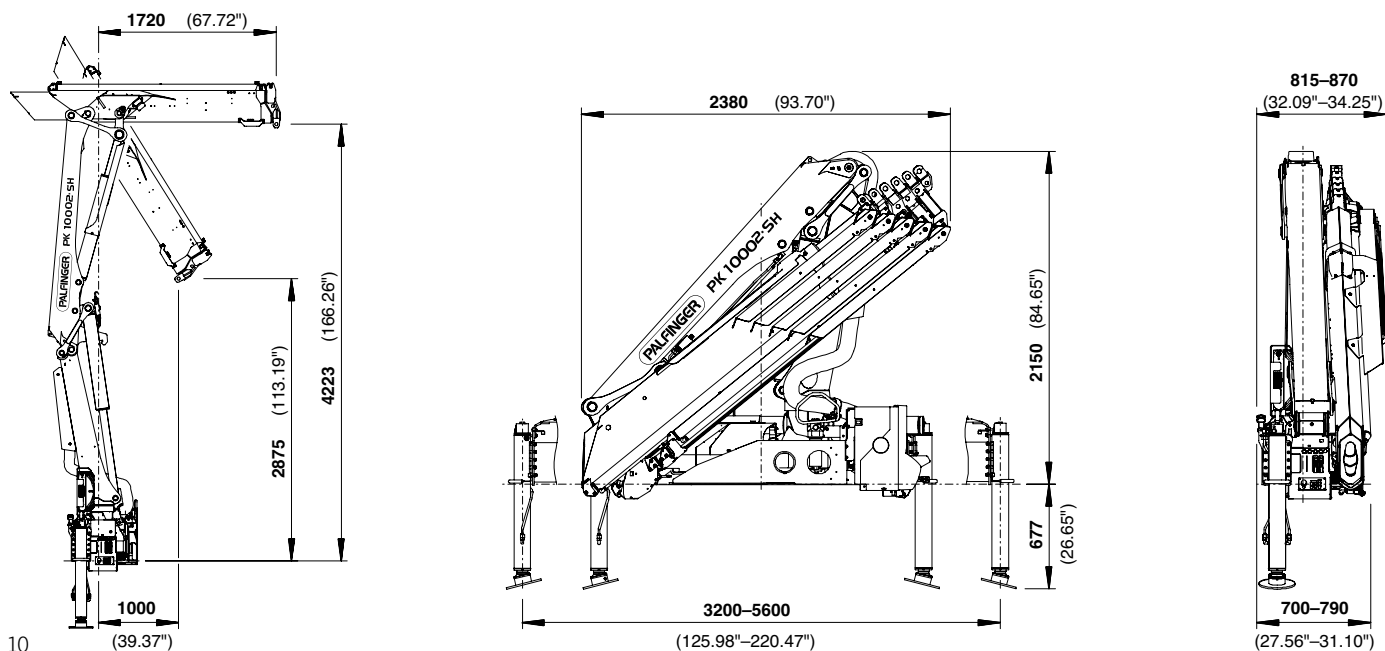



Technical specifications

EN 12999 HC1 HD5/B3

PK 10002 SH

Max. lifting moment	9.4 mt/91.9 kNm	67780 ft.lbs
Max. lifting capacity	5700 kg/55.9 kN	12570 lbs
Max. hydraulic outreach	14.1 m	46' 3"
Max. manual outreach	16.1 m	52' 10"
Slewing angle	400°	
Slewing torque	1.0 mt/9.8 kNm	7230 ft.lbs
Stabiliser spread (std./max.)	3.2 m / 5.6 m	10' 6" / 18' 4"
Fitting space required (std.)	0.70 m	2' 4"
Width folded	2.38 m	7' 10"
Max. operating pressure	365 bar	5293 psi
Recommended pump capacity	from 40 l/min to 50 l/min	10.6 US gal./min 13.2 US gal./min
Dead weight (std.)	1070 kg	2359 lbs

PK 12502 SH

HIGH PERFORMANCE

Proven in continuous situations.

STD

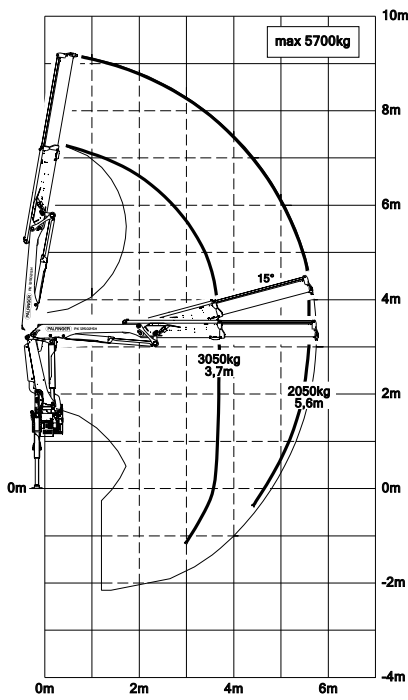

A

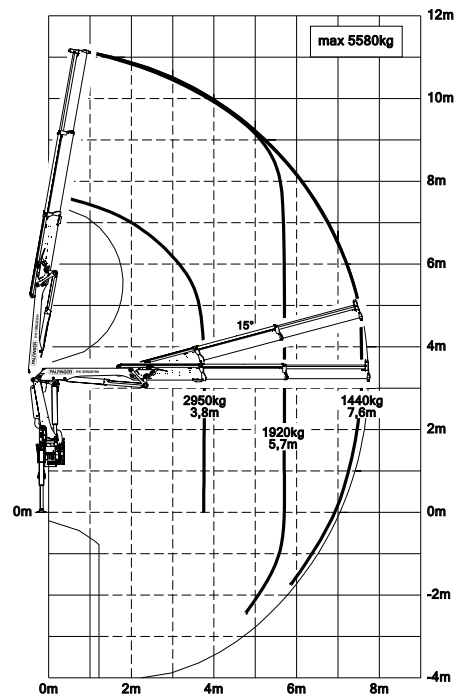

C

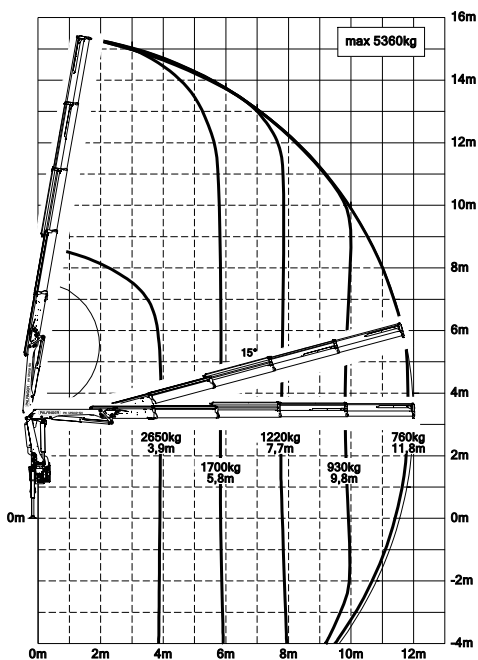

D

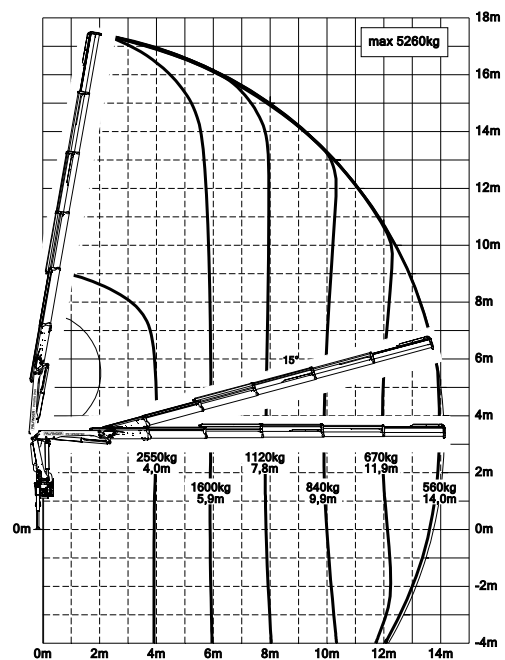

The outreaches stated are with a boom angle of 20° and are therefore not the maximum.

Lifting capacities

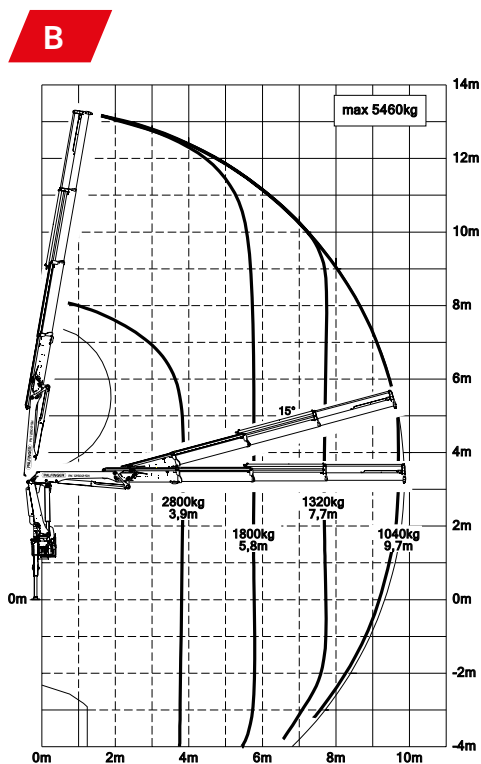

max.		5700 kg	55.9 kN	STD
3.7 m	12' 2"	3050 kg	6800 lbs	
5.6 m	18' 4"	2050 kg	4500 lbs	

max.		5580 kg	54.7 kN	A
3.8 m	12' 6"	2950 kg	6500 lbs	
5.7 m	18' 8"	1920 kg	4250 lbs	
7.6 m	24' 11"	1440 kg	3150 lbs	

max.		5460 kg	53.6 kN	B
3.9 m	12' 10"	2800 kg	6200 lbs	
5.8 m	19' 0"	1800 kg	4000 lbs	
7.7 m	25' 3"	1320 kg	2900 lbs	
9.7 m	31' 10"	1040 kg	2300 lbs	
11.9 m*	39' 1"	800 kg	1760 lbs	
13.9 m*	45' 7"	660 kg	1460 lbs	

max.		5360 kg	52.6 kN	C
3.9 m	12' 10"	2650 kg	5900 lbs	
5.8 m	19' 0"	1700 kg	3750 lbs	
7.7 m	25' 3"	1220 kg	2700 lbs	
9.8 m	32' 2"	930 kg	2050 lbs	
11.8 m	38' 9"	760 kg	1680 lbs	
13.8 m*	45' 3"	620 kg	1380 lbs	
15.8 m*	51' 10"	380 kg	840 lbs	

max.		5260 kg	51.6 kN	D
4.0 m	13' 1"	2550 kg	5600 lbs	
5.9 m	19' 4"	1600 kg	3550 lbs	
7.8 m	25' 7"	1120 kg	2500 lbs	
9.9 m	32' 6"	840 kg	1840 lbs	
11.9 m	39' 1"	670 kg	1480 lbs	
14.0 m	45' 9"	560 kg	1240 lbs	
16.0 m*	52' 6"	380 kg	840 lbs	

*mechanical extension

PERFECT DIMENSIONS

EXTENSION BOOM VARIATIONS

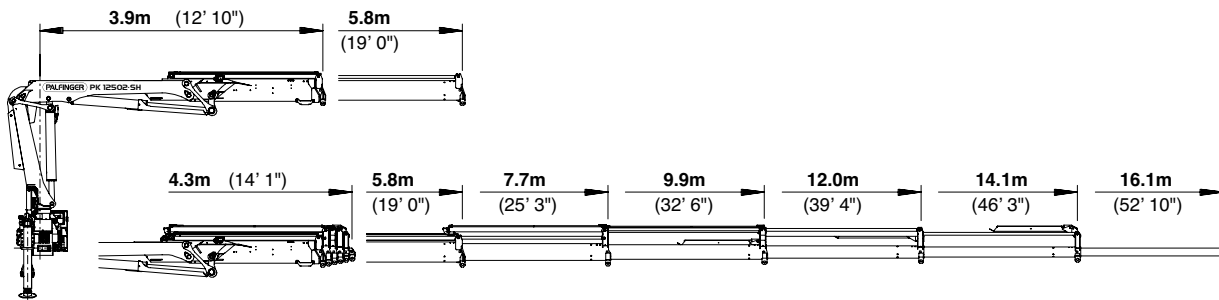

DIMENSIONS

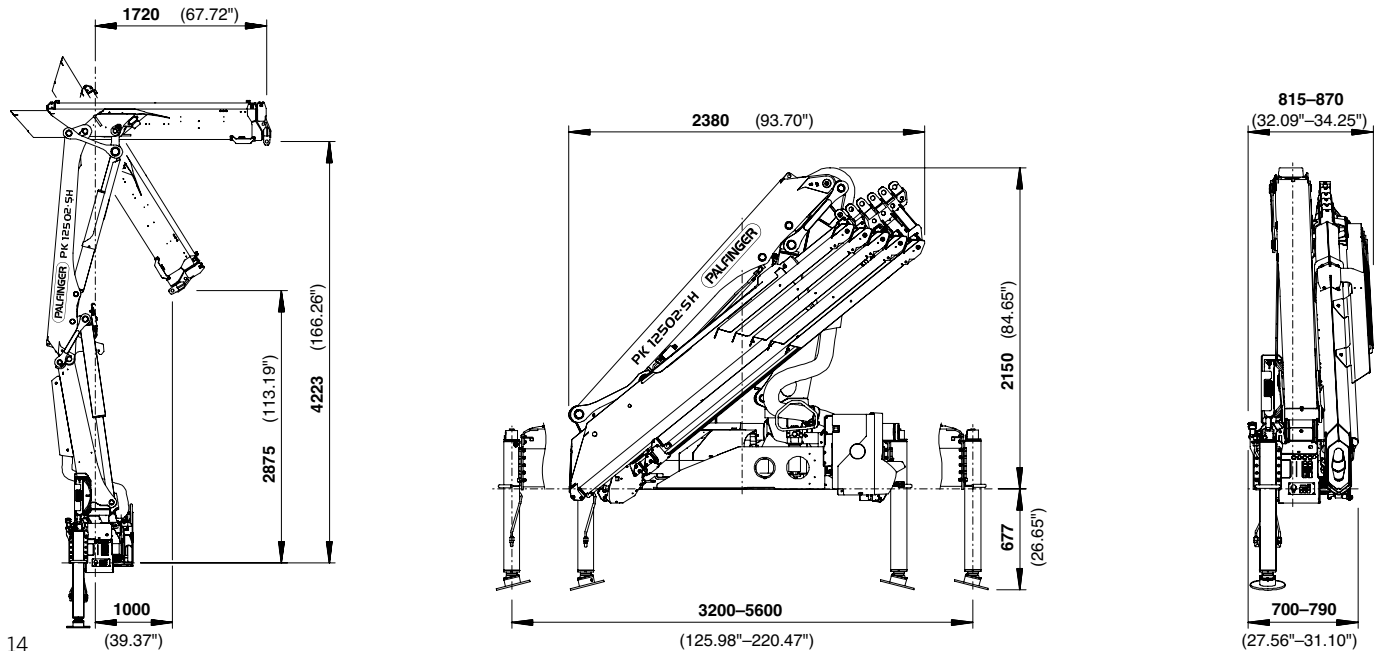

Technical specifications

EN 12999 HC1 HD5/B3

PK 12502 SH

Max. lifting moment	11.4 mt/112.0 kNm	82600 ft.lbs
Max. lifting capacity	5700 kg/55.9 kN	12570 lbs
Max. hydraulic outreach	14.1 m	46' 3"
Max. manual outreach	16.1 m	52' 10"
Slewing angle	400°	
Slewing torque	1.3 mt/12.7 kNm	9370 ft.lbs
Stabiliser spread (std./max.)	3.2 m / 5.6 m	10' 6" / 18' 4"
Fitting space required (std.)	0.70 m	2' 4"
Width folded	2.38 m	7' 10"
Max. operating pressure	365 bar	5293 psi
Recommended pump capacity	from 45 l/min to 60 l/min	11.9 US gal./min 15.9 US gal./min
Dead weight (std.)	1160 kg	2557 lbs



KP-H10/12502SM2+EN

Cranes shown in the leaflet are partially optional equipped and do not always correspond to the standard version. Country-specific regulations must be observed. Dimensions may vary. Subject to technical changes, errors and translation mistakes.