

MERCEDES

P 280 B

BENZ SPRINTER 315 CDI 4X2

CONTRACT NUMBER: P280B STANDARD

NEW

IN PRODUCTION



SPECIFICATION

OFFER INFORMATION

Location details

Löbau, 02708 - Germany 

Dealer Name

Palfinger Platforms GmbH

Product type

New

Contract number

P280B Standard

Dealer E-mail

sales.platforms@palfinger.com

Dealer phone

004935854796121

- Covers made of aluminium chequer plate
- Home-Function
- Operator control panel in cage (optional display possible)
- Stabilizer control panel at the base
- Automatic stabilizer levelling system
- Three stabiliser configurations: jacking within vehicle width, wide jacking and one-side wide jacking and automatic release of the related workspace
- 1x user manual, signs, display language (if display is present) in country specific language
- 230V/10A CEE-socket incl. supply with residual current circuit breaker at the base
- 230V CEE-socket at cage
- Additional CEE-socket supplied by on-board voltage
- Cleaning hatch at cage
- Self-closing door for upright entrance to the cage
- 2 anchor points for safety harnesses
- PALDiag for system analysis, integrated in platforms software

Painted in MB9147 arctic white

PRODUCT

Manufacturer	PALFINGER	Turret rotation	500°
Model	P 280 B	Basket size	1,40 x 0,70 x 1,10 m
Construction year	NEU - NEW	Basket capacity	250 kg
Outreach	17,00 m	Basket turning device	+/- 90°
Max. height of work	27,60 m	Basket material	Aluminum

TRUCK

Truck manufacturer	Mercedes Benz	Power	110 kW (150 PS)
Vehicle type	Sprinter 315 CDI	Emmission standard	EURO 6
Construction year	NEU - NEW	Axes	4x2
Wheel base	3.665 mm	Gross vehicle weight	3.500 kg

PALFINGER

P 280 B

LIGHT CLASS NX

LIFETIME EXCELLENCE



TECHNICAL SPECIFICATIONS

Max. working height	27.60 m
Max. cage bottom height	25.60 m
Max. outreach*	17.00 m
Rotation angle of turnable	500°
Rotation angle of cage	2 x 90°
Max. cage load	250 kg
Size of cage	1.40 x 0.70 x 1.10 m
Max. inclination of platform	5°
Height in transportposition*	2.90 m
Width in transportposition*	2.22 m
Overall length*	6.99 m
Wheelbase*	2900 mm
Total weight*	3500 kg

* depending on the truck chassis

STANDARD EQUIPMENT

Home function
Automated positioning system
Safety plates
EEC typo approval
Stabilizer control at basis and cage
Enormous options

TECHNICAL DRAWING

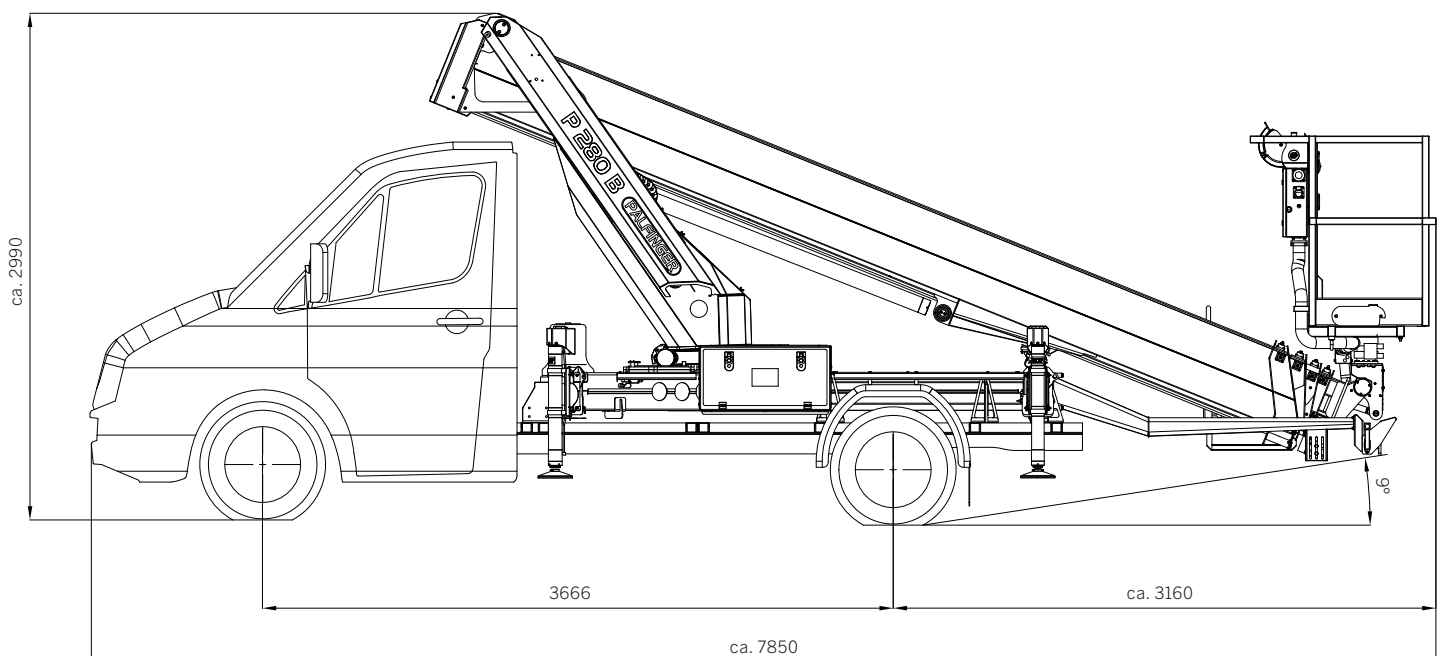

KP-P280BM2+EN

Units shown in the leaflet are partially optional equipped and do not always correspond to the standard version. Country-specific regulations must be observed. Dimensions may vary. Subject to technical changes, errors and translation mistakes.

Platforms | Area sales Manager



Head of sales
Michael Gruböck



Laura Garagnani
Responsible Areas:
France, Portugal, Spain



Timo Lenzen
Responsible Areas: Norway, Sweden, Finland, Island, Denmark, Faroe Islands, Latvia, Lithuania, Estonia, Czech Republic, Poland, Ukraine, Moldova



Adnan Isso
Responsible Areas:
Netherlands, Belgium, Luxembourg



Mohammed AlNajmi
Responsible Areas: Slovenia, Croatia, Greece, Cyprus, Serbia, Bosnia, Kosovo, Montenegro, Albania, Macedonia, Israel, Turkey, Georgia, Syria, Lebanon, Jordan, Iraq, Iran, Afghanistan, Saudi Arabia, Kuwait, Bahrain, Qatar, UAE, Oman, Yemen



Dieter Schlosser
Responsible Areas:
Switzerland, Slovakia, Hungary, Romania, Bulgaria, Australia, New Zealand, Georgia, Ireland, United Kingdom



Johann Poschner
Responsible Areas:
Germany, Austria



ALFREDO CAREDDU
Responsible Areas:
Italy, Malta



Mohammed AlNajmi
Responsible Areas:
Africa

