

MERCEDES

P 250 BK

BENZ SPRINTER 315 CDI 4X2

CONTRACT NUMBER: P250BK STANDARD

NEW

IN PRODUCTION



SPECIFICATION

OFFER INFORMATION

Location details

Löbau, 02708 - Germany 

Dealer Name

Palfinger Platforms GmbH

Product type

New

Contract number

P250BK Standard

Dealer E-mail

sales.platforms@palfinger.com

Dealer phone

004935854796121

- 4 Safety-Spreader plates incl. bracket on the platform covering
- Covers made of aluminium chequer plate
- Home-Function
- Operator control panel in cage (optional display possible)
- Stabilizer control panel at the base
- Automatic stabilizer levelling system
- Three stabiliser configurations: jacking within vehicle width, wide jacking and one-side wide jacking and automatic release of the related workspace
- 1x user manual, signs, display language (if display is present) in country specific language
- 230V/10A CEE-socket incl. supply with residual current circuit breaker at the base
- 230V CEE-socket at cage
- Additional CEE-socket supplied by on-board voltage
- Cleaning hatch at cage
- Self-closing door for upright entrance to the cage
- 2 anchor points for safety harnesses
- PALDiag for system analysis, integrated in platforms software

Painted in MB9147 arctic white

PRODUCT

Manufacturer	PALFINGER	Basket size	1,40 x 0,70 x 1,10 m
Model	P 250 BK	Basket capacity	250 kg
Construction year	NEU - NEW	Basket turning device	+/- 90°
Outreach	16,9 m	Basket arm angle	185°
Max. height of work	24,7 m	Basket material	Aluminium
Turret rotation	500°		

TRUCK

Truck manufacturer	Mercedes Benz	Power	110 kW (150 PS)
Vehicle type	Sprinter 315 CDI	Emmission standard	EURO 6
Construction year	NEU - NEW	Axes	4x2
Wheel base	3.665 mm	Gross vehicle weight	3.500 kg

P 250 BK

LIGHTWEIGHT AND VERSATILE

LIFETIME EXCELLENCE

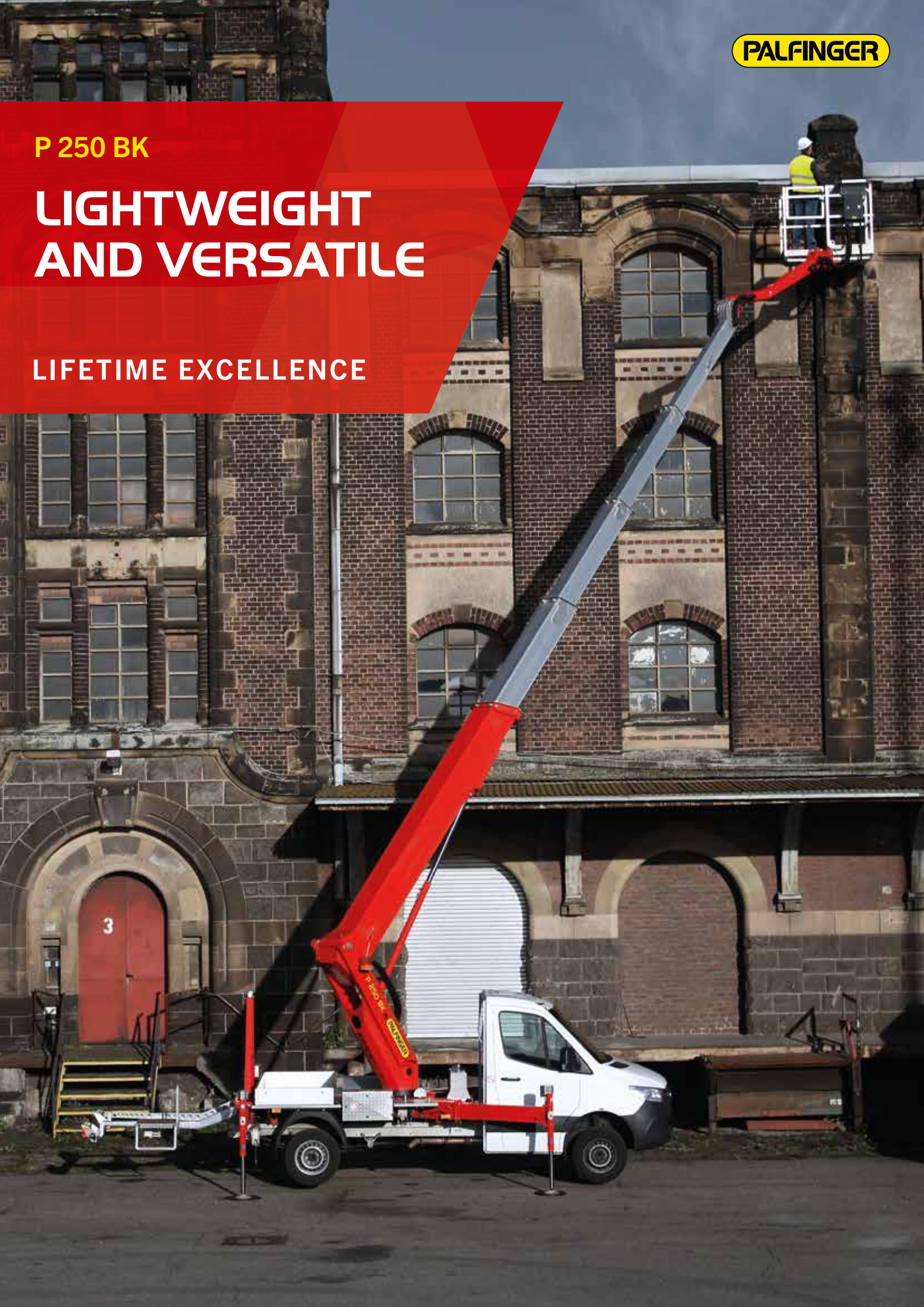

HIGHLIGHTS

- Outrigger control panel located at the rear end for a safe operation. All outriggers are visible from this position.
- The control panel in the cage enables a safe and efficient operation of the platform
- Even with a cage load of 250kg the full working height can be reached.
- Three stabiliser configurations: in contour, fully extended and one side extended only as well as the automatic adjustment of the corresponding working envelope
- Flat substructure under the cage allows users to get close to objects

STANDARDS















- Home function
- Automated positioning system
- 4 Safety plates
- 230V CEE current supply with CEE socket in the workman basket
- European type approval
- Stabilizer control at basis

OPTIONS

- Tree cutting package (tool tray inside the cage, bracket for chainsaw, dividing screen, wooden frame, working lights and illumination of surrounding area)
- Attachment point for load securing nets
- Bracket inclusive 7 traffic cones
- Cable remote control to connect at the base
- Display in addition to the control panel
- Insulation package in combination with aluminum cage



TECHNICAL SPECIFICATIONS

	Total weight *	3390 kg		max. outreach to the side	13.3 m
	Overall length	7.71 m		max. outreach	16.9 m
	Total width	2.22 m		Angle of main boom	500°
	Travelling height	2.99 m		Rotation angle of cage	2 x 90°
	Wheelbase	3665 mm		Rotation angle of cage boom	185°
	max. working height	24.7 m		Size of cage	1.40 x 0.70 x 1.10 m
	max. cage bottom height	22.7 m		max. cage load	250 kg

* Depends on truck chassis

WORKING DIAGRAMS

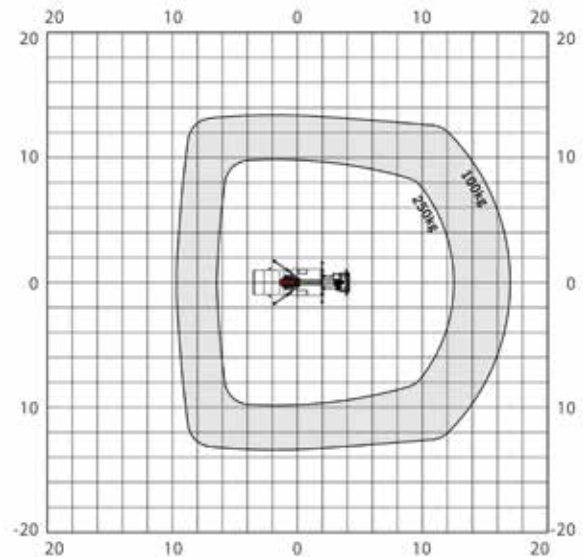
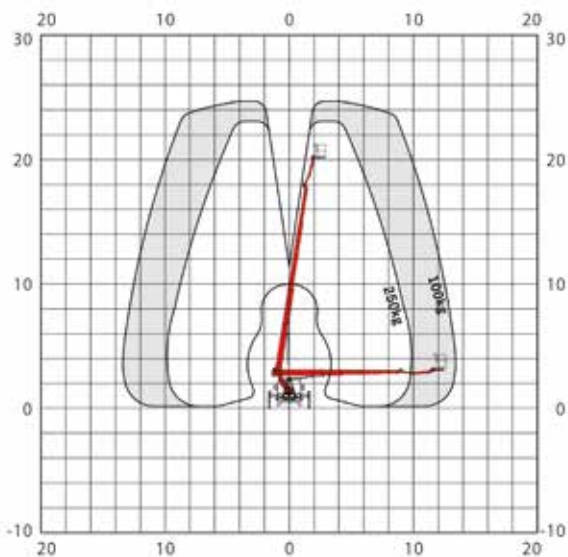

* A possible 2% tolerance is contingent on structural components

DIMENSIONS

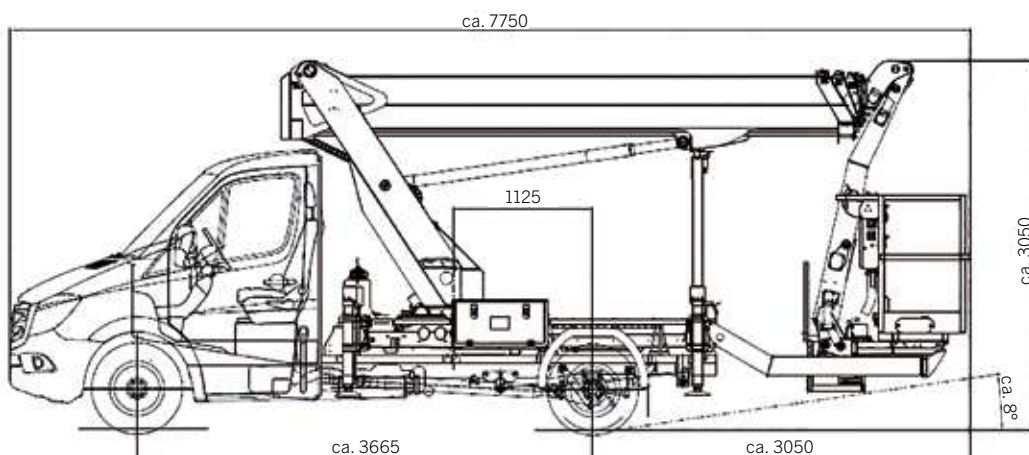

YOUR CONTACT

Palfinger Platforms GmbH

Düsseldorfer Str. 100
47809 Krefeld | Germany

KP-P250BKM3+EN

Units shown in the leaflet are partially optional equipped and do not always correspond to the standard version. Country-specific regulations must be observed. Dimensions may vary. Subject to technical changes, errors and translation mistakes.

Platforms | Area sales Manager



Head of sales
Michael Gruböck



Laura Garagnani
Responsible Areas:
France, Portugal, Spain



Timo Lenzen
Responsible Areas: Norway, Sweden, Finland, Island, Denmark, Faroe Islands, Latvia, Lithuania, Estonia, Czech Republic, Poland, Ukraine, Moldova



Adnan Isso
Responsible Areas:
Netherlands, Belgium, Luxembourg



Mohammed AlNajmi
Responsible Areas: Slovenia, Croatia, Greece, Cyprus, Serbia, Bosnia, Kosovo, Montenegro, Albania, Macedonia, Israel, Turkey, Georgia, Syria, Lebanon, Jordan, Iraq, Iran, Afghanistan, Saudi Arabia, Kuwait, Bahrain, Qatar, UAE, Oman, Yemen



Dieter Schlosser
Responsible Areas:
Switzerland, Slovakia, Hungary, Romania, Bulgaria, Australia, New Zealand, Georgia, Ireland, United Kingdom



Johann Poschner
Responsible Areas:
Germany, Austria



ALFREDO CAREDDU
Responsible Areas:
Italy, Malta



Mohammed AlNajmi
Responsible Areas:
Africa

