



LIFTGATES

ILK

OWNER'S MANUAL

ECN-M0605 Rev. 1.4, Date 06-11-15 Part #90-0413-100

PALFINGER Liftgates, LLC. 15939 Piuma Ave., Cerritos, CA 90703
Tel (888)-774-5844 Fax (562)-924-8318

PALFINGER Liftgates, LLC. 572 Whitehead Road, Trenton, NJ 08619
Tel (609)-587-4200 Fax (609)-587-4201

Visit our website at www.palfinger.com for up to date information and notifications

If you received this product with damaged or missing parts,

Please contact PALFINGER Liftgates at (888)-774-5844

Table of Content

Table of Figures	II
1. Important Notes	1
1.1 Attention	1
1.2 Important Notes	1
1.3 General Information	2
2. Safety Information	4
3. Basic Parts in Detail	6
3.1 General View of Liftgate	6
3.2 Circuit Board Connector Cables	7
3.3 Control Panel.....	8
4. Maximum Load and Placing of Load on Platform	9
5. Operation of Liftgate	11
5.1 Operation by Control Box	11
5.2 Operation by Hand Held Remote Control.....	12
5.3 Operation by Foot Control (optional).....	13
5.4 Operation by Wireless hand Held Remote (optional)	13
5.5 Application of the Liftgate for Dock Loading.....	14
6. Preventive Maintenance and Quick Check	15
6.1 Maintenance and Care	15
6.2 Lubrication.....	16
6.2.1 Lubrication Plan	16
6.2.2 Checking and Changing the Oil.....	17
6.2.3 Recommended Hydraulic Fluids	17
6.3 Decal Placement and Inspection	18
6.4 Quick Check List.....	20
7. Troubleshooting	21
7.1 Basic Function Check.....	21
7.1.1 LIFTGATE is competely DEAD (No Clicking or Movement at all)	21
7.1.2 On-Off L.E.D.s are on but all functions are dead.....	23
7.1.3 L.E.D.s continue to stay on, after switch is turned off	24
7.1.4 Platform tilts down before it reaches the ground.....	24
7.2 Possible cause & remedy of liftgate malfunction.....	25
7.3 Electrical and Hydraulic Schematic.....	29
7.3.1 Wiring Diagram - Truck	29
7.3.2 Electrical Schematic.....	31
7.3.3 Connector Overview	32

7.3.4	Hydraulic Schematic	33
8.	Needed Information for Ordering Spare Parts and Repairs	34
8.1	Ordering Spare Parts.....	34
8.2	Repairs.....	34
9.	Warranty	35
10.	Contact Address	36

Table of Figures

Figure 1: ILK Cantilever.....	6
Figure 2: Center Point of Load.....	9
Figure 3: Load Diagram (ILK Plus 33).....	9
Figure 4: Load Diagram (ILK Plus 44 to 66)	10
Figure 5: Lube Points	16
Figure 6: Power Pack (Side and Top View)	17
Figure 7: Decal Placement Guideline	19
Figure 9: Electrical Schematic	31
Figure 10: Connector Overview	32
Figure 11: Hydraulic Schematic.....	33

List of Tables

Table 1: Maintenance Schedule	15
Table 2: Recommended Hydraulic Fluids	17
Table 3: Warranty Coverage Schedule	35

1. Important Notes

1.1 Attention

Before starting any operations of the liftgate, please read and understand this OWNER'S MANUAL. Its intention is to act as a guide for the operation personal as well as to give help with preventive maintenance but does not take place of unauthorized usage or repair by unqualified personnel.

Please contact your nearest PALFINGER Liftgates distributor or PALFINGER Liftgates in California or New Jersey for assistance if you have questions regarding installation, operation or maintenance.

This owner's manual applies to the following models: **ILK Plus 22, 33, 44, 55 & 66**



This is the safety alert symbol. It is used to alert you to potential personal injury hazards. Obey all safety messages that follow this symbol to avoid possible injury.

1.2 Important Notes

The Palfinger liftgate is a cantilever design, electro-hydraulically driven liftgate.

The Hydraulic Power Unit (HPU) is easily accessible for service and exchange. The whole assembly slides out and can be serviced at that point. To exchange the HPU, two hoses and the battery cables need to be disconnected.

The platform is supported by two arms, linked with a torsion tube. A three piece under ride guard is preinstalled on the liftgate.

Lifting actions are carried out by the two hydraulic lift cylinders mounted on the lift arms.

Two hydraulic tilt cylinders, mounted outside of each lift arm are controlling the platform's tilting action. This enables the platform to maintain its position throughout the lift mode, regardless of the terrain.

The hydraulic cylinders are equipped with solenoid operated release valves, located at the port of each cylinder. This prevents the platform from moving unless the operator is activating the controls. This system also enables you to store the liftgate without a separate platform latch.

The piston rods are treated against corrosion and also protected with plastic or rubber boots to protect from road gravel and dirt. The Hydraulic Power Unit is equipped with a built-in pressure relief valve, which prevents overloading when lifting and tilting up.



The valves do not prevent overloading of the platform when lowering or tilting down.



The electric supply is taken from the vehicle battery. If the vehicle battery is not sufficient, an auxiliary battery kit needs to be installed. The electric control power is secured via a 20 Amp fuse and an on-off switch located inside the cab. The switch has L.E.D. lights indicating when the control power is on. (Trailer application has the on-off switch located in the lockable control box.)

The liftgate is operated from an outside mounted control box which is located on the curbside underneath the body. A standard 3-button hand held remote control is also supplied with the lift. A variety of different control options can be purchased with the PALFINGER Liftgates product.

1.3 General Information

REMEMBER!

It is the fleet manager's responsibility to educate the operator on the liftgate and its intended use. The operator's attention should be drawn to the permitted load limits and an understanding of the operation to ensure the safety throughout the operation.

ONE-MAN OPERATION!

Never let an "outsider" operate the liftgate while you are handling the cargo.

A "misunderstanding" can result in serious personal injury.



In the interest of safety it is important that all operating personnel properly understand the functions of the liftgate, possible hazards, dangers, the load limits and load positioning for that specific unit.

IMPORTANT NOTICE!



Before the operator uses the liftgate, they should be thoroughly familiar with the lift's functions and usage according to the following:

1. Improper operation of this lift can result in serious personal injury. Do not operate unless you have been properly instructed, have read and are familiar with the operation instructions. If you do not have a copy of the instructions please obtain them from your employer, distributor or lessor, as appropriate, before you attempt to operate the liftgate.
2. Be certain the vehicle is properly and securely stopped before using the liftgate.
3. Always maintain the liftgate and inspect it for damage before usage. If there are signs of improper maintenance, damage to vital parts or slippery platform surface, do not use the liftgate. Do not attempt your own repairs unless you are specifically trained.

4. Do not overload. See the Rating Label on the unit for the rated load. Remember that this limit applies to both raising and lowering operations.
5. Each load should be placed in a stable position as near as possible to the body of the truck/trailer.
6. Never stand in, move through or allow anyone else to stand in or move through the area in which the lift operates, including that area in which a load might fall.
7. This is not a passenger lift. Do not ride the lift with unstable loads or in such a manner that a failure would endanger you. The lift is not equipped with a back-up system to prevent falling cargo in the event of a failure.

The maximum loads must be observed and followed!



IMPROPER USE



It is not permitted to use the tail lift:

- As an elevating work platform.
- To push loads.
- To carry people (Only the operator may travel on the platform).
- To clear snow.

Please read through the operational and technical description of the PALFINGER Liftgate.

Thank you for choosing PALFINGER Liftgates.

2. Safety Information

This manual follows the Guidelines set forth in "ANSI Z535.4-2007" for alerting you to possible hazards and their potential severity.

DANGER

! **DANGER** indicates an imminently hazardous situation which, if not avoided, **will result** in death or serious injury.

WARNING

! **WARNING** indicates a potentially hazardous situation which, if not avoided, **could result** in death or serious injury.

CAUTION

! **CAUTION** indicates a potentially hazardous situation which, if not avoided, **may result** in minor or moderate injury.

CAUTION

CAUTION without the safety alert symbol is used to address practices not related to personal injury.

(In this manual we use it to alert you to a potentially hazardous situation which, if not avoided, may result in property damage.)

NOTICE

NOTICE without the safety alert symbol is used to address practices not related to personal injury.

(In this manual we use it to alert you to special instructions, steps, or procedures.)

⚠ WARNING

Improper operation of this liftgate may result in severe personal injury or death. DO NOT operate unless you have been properly instructed and have read, and are familiar with the procedures in this manual. We have designed this manual to illustrate the steps needed for the basic operation of this ILK liftgate. It also provides safety information and simple preventive maintenance tips.

NOTICE

This manual is not intended for use as a repair or troubleshooting guide. Repairs should be performed by a PALFINGER Liftgates Authorized Service Center.

This Manual has been designed for use in conjunction with the ILK series liftgate only which is designed for different capacities. You have different options to determine the type of your Liftgate:

- 1) Refer to the serial number tag on the Liftgate (Driver Side on Top of Mount Frame).
- 2) Ask your employer or lessor.
- 3) Call your PALFINGER Liftgates Authorized Service Center for assistance.
- 4) Call PALFINGER Liftgates for assistance in the USA at 888-774-5844. You can also contact PALFINGER Liftgates by fax (562) 924-8318, or on the internet- www.PALFINGER.com

If you are facing any problems or are in need of repair, contact PALFINGER Liftgates for information regarding experienced and trained Authorized Service Center in your area.

- 5) Maintain this manual in the vehicles cab at all times. Replacement manuals are available, just call us & order your manuals for FREE or download from www.palfinger.com.

3. Basic Parts in Detail

3.1 General View of Liftgate

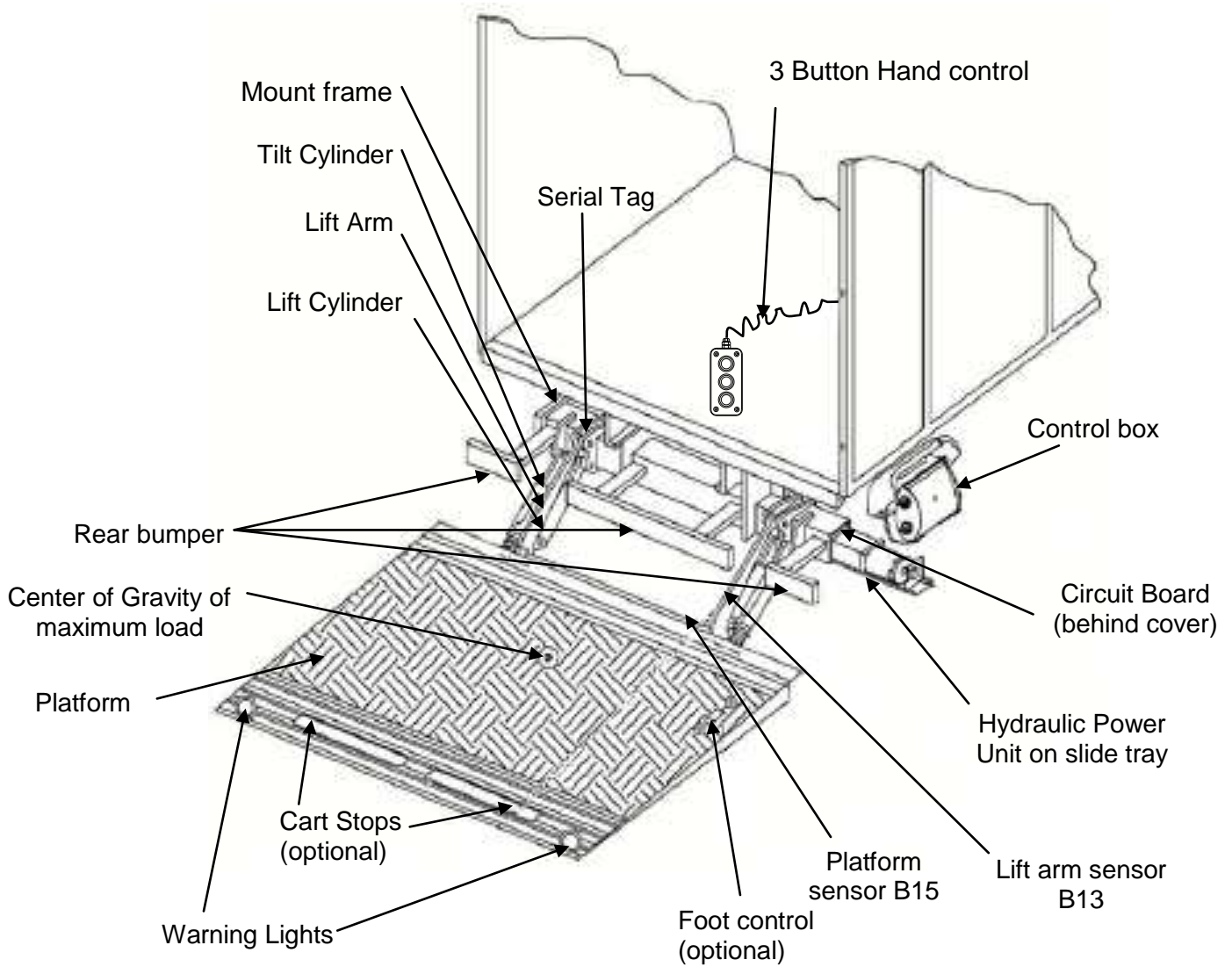
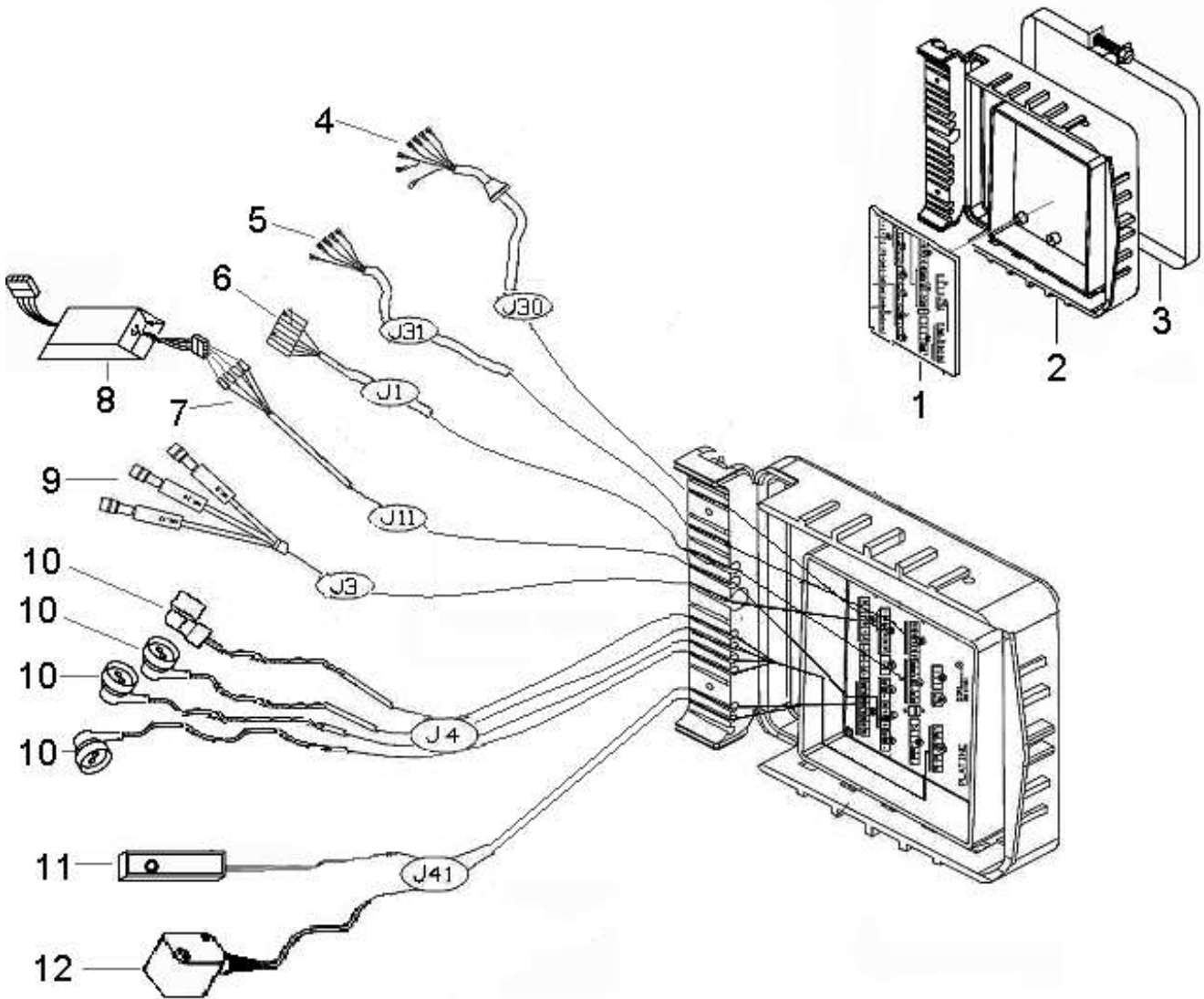

Figure 1: ILK Cantilever

3.2 Circuit Board Connector Cables



No.	Description	Part No.
1	PC- board	P-200 7193K
2	Cover for control system	P-200 7474
3	Clamp for cover	P-201 0169
4	Wire harness for control box (J30)	P-200 7295
5	Wire harness for hand control (J31)	P-200 8921
6	Wire harness for power pack (J1)	P-200 7298
7	Wire harness for cab on-off switch (J11)	P-200 7049
8	Power relay for J11	P-200 7044
9	Wire harness for warning lights and foot control (J3)	P-134 2776
10	Cable for solenoid valve (J4)	P-6725 4198
11	Sensor B13 for lift arm (J41)	P-133 2476
12	Sensor B15 for platform (J41)	P-133 2485

3.3 Control Panel

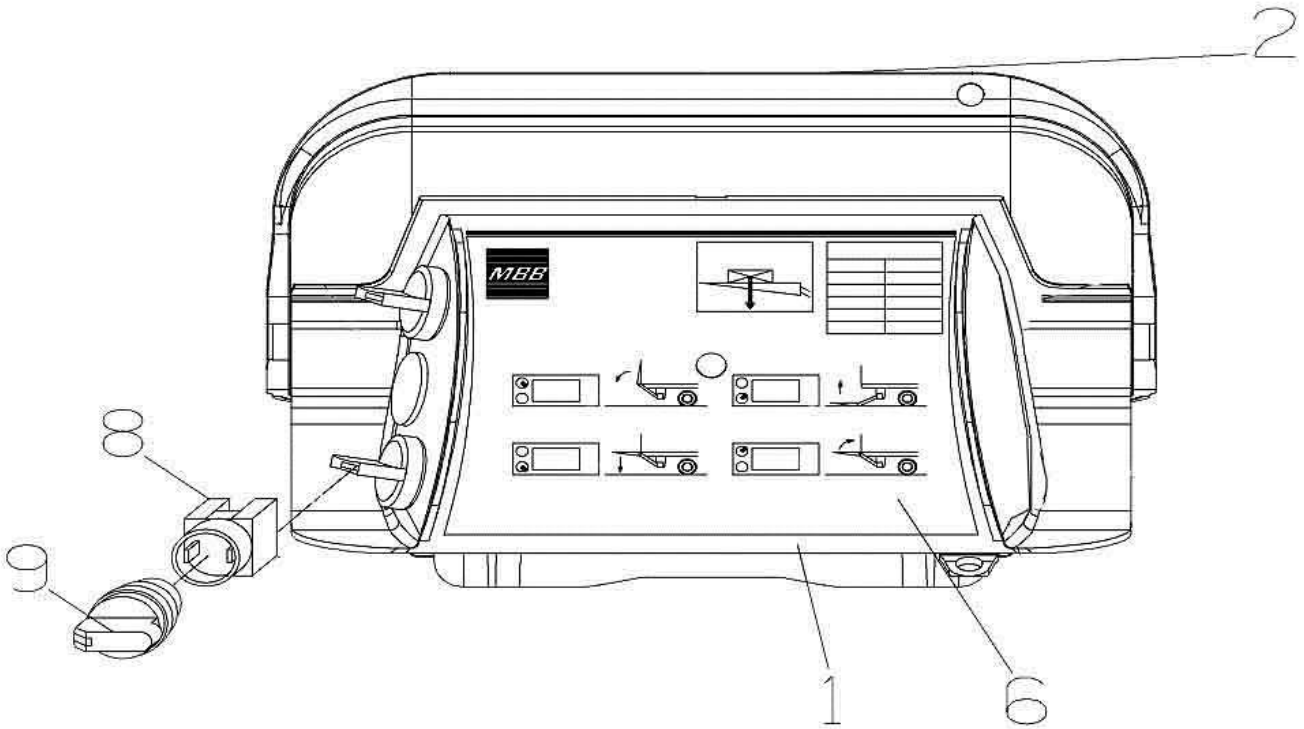

No.	Description	Part number
1	CONTROL PANEL OUTER BOX	P-2009205
2	CONTROL BOX LID	P-2007476
6	LABEL	P-2007278
8	CONTACT BLOCK	P-2007457
9	MOMENTARY TURN SWITCH	P-2007456

4. Maximum Load and Placing of Load on Platform

Every PALFINGER liftgate is rated up to a maximum load. The point of maximum load is rated at a defined distance. The center point of maximum load is at 24" (2000 to 3300 lbs) or at 30" (4400 to 6600 lbs) from start of Truck or Trailer Body, as shown in Figure 2.

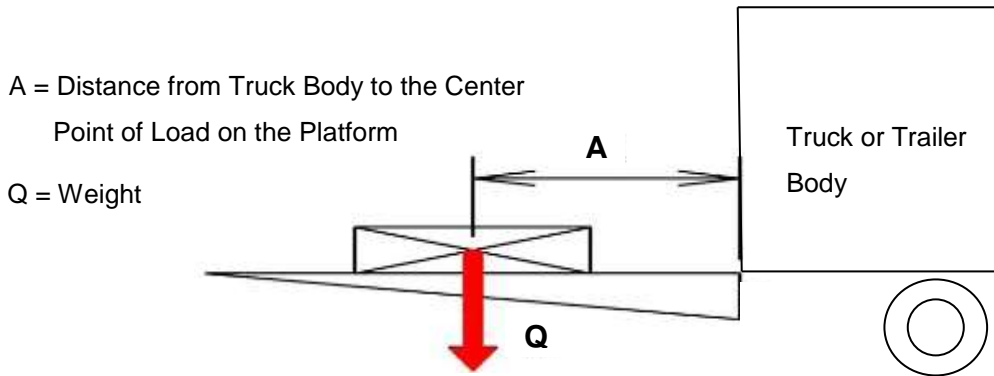

Figure 2: Center Point of Load



By increasing this distance the maximum load of the liftgate is decreasing.



An overview about the rating, depending on the distance from the end of the platform, is shown in the following load diagram.

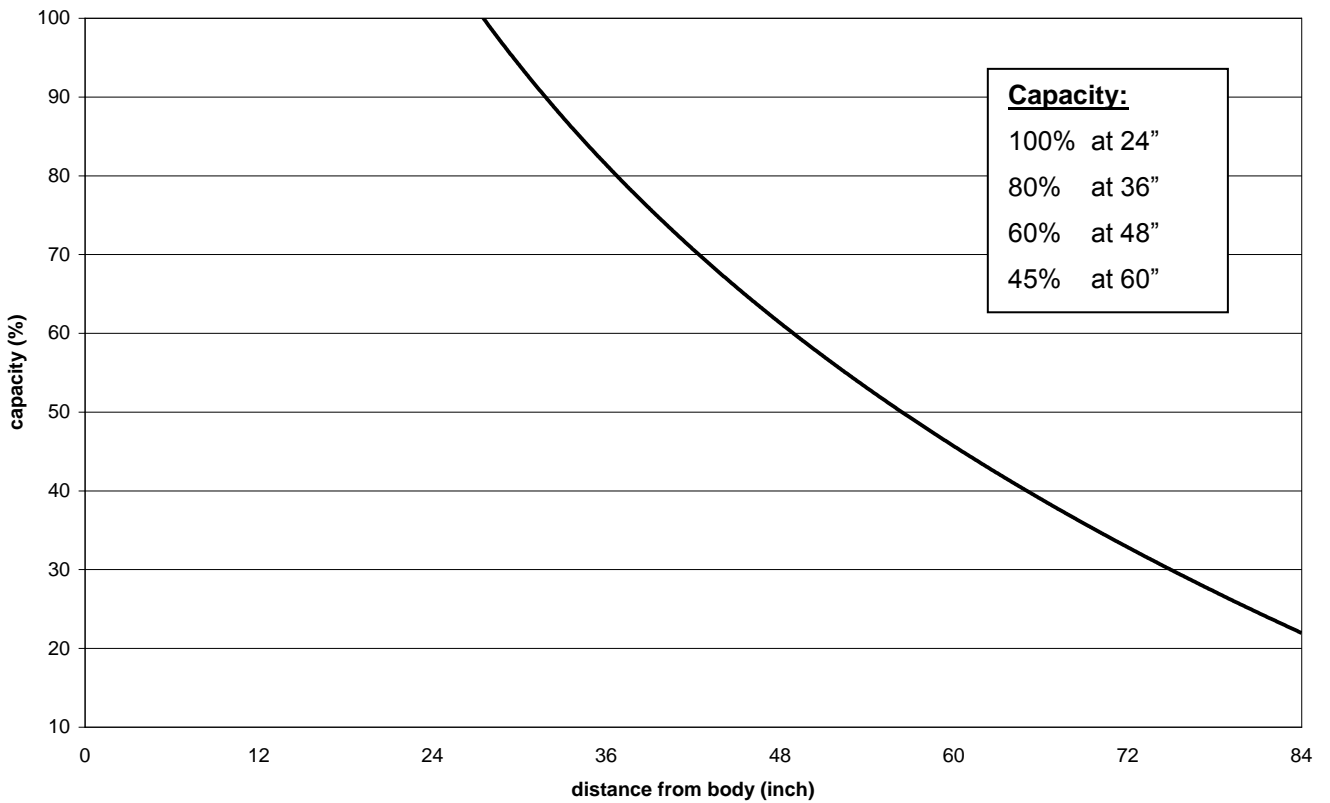

Figure 3: Load Diagram (ILK Plus 33)

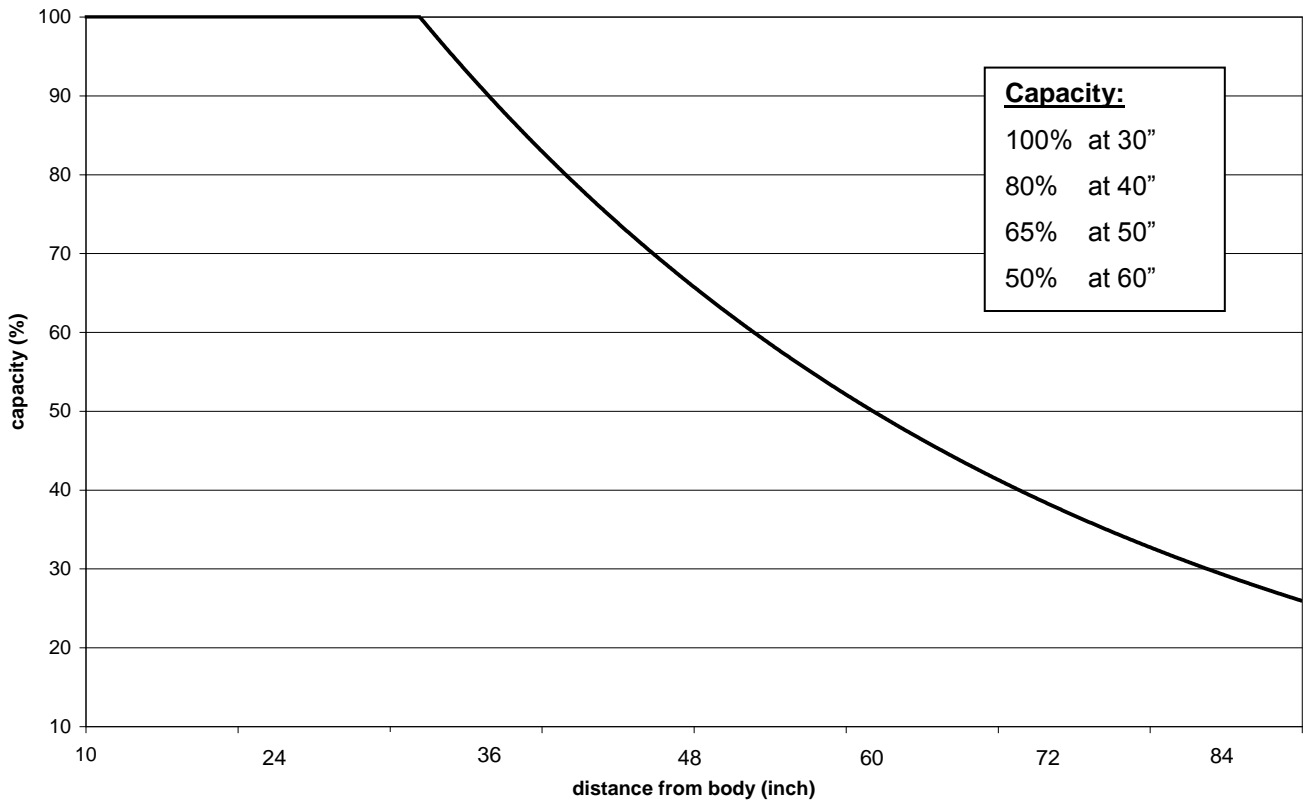

Figure 4: Load Diagram (ILK Plus 44 to 66)

5. Operation of Liftgate

Before use: Turn Control switch to "ON", the L.E.D.'s will light up inside the cab. All liftgate functions can be controlled by the 2-switch control box, which is mounted on the curb side of the truck or trailer.

5.1 Operation by Control Box

1. LOWER PLATFORM FROM STORED POSITION

To lower the platform from stored position use the **Tilt** switch **DOWN**.

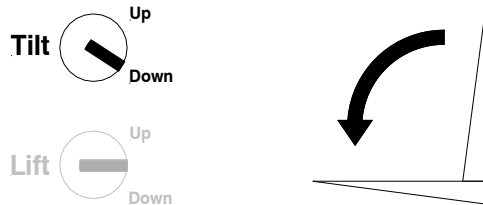

2. LOWERING PLATFORM AND TILT DOWN AT GROUND

To lower the platform down from bedheight use the **Lift** switch **DOWN**. After the platform reaches ground, the tip will tilt down if the operator continues to turn the bottom switch.

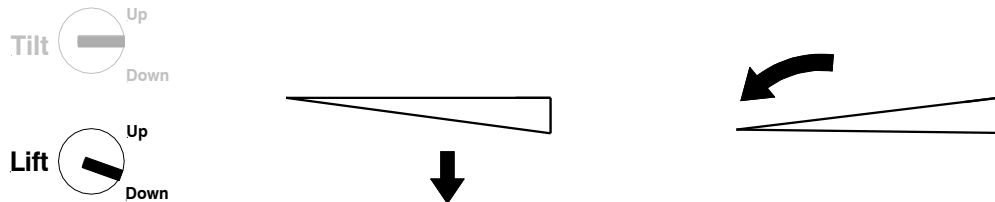

3. TILT UP AND LIFT FROM GROUND

To lift up platform use the **Lift** switch **UP** (the platform will find level position before starting to raise)..

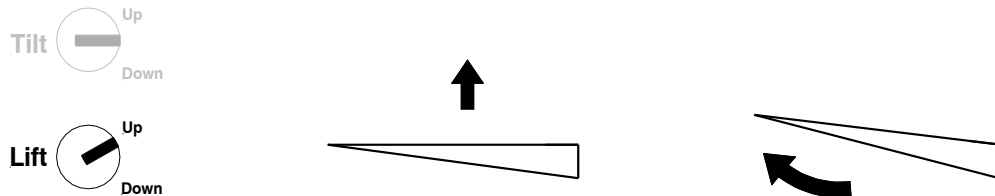

4. CLOSING PLATFORM

To close platform, use the **Tilt** switch **UP** (always raise the gate to bed level before closing the platform).

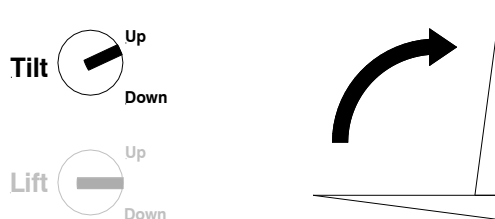

5.2 Operation by Hand Held Remote Control

1. LOWERING DOWN:
Push button number 3
2. LIFTING UP:
Push button number 1

Tilt functions: Push button number 2 while lifting or lowering

1. TILT DOWN:
Push button 2 and 3 at the same time
2. TILT UP:
Push button 2 and 1 at the same time

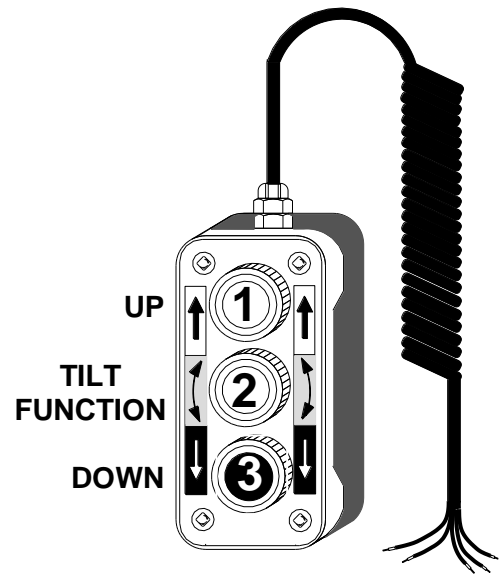

5.3 Operation by Foot Control (optional)

DOWN:

Step on switch 1 and hold – wait between one and three seconds before you step on switch 2.
 → For auto tilt, stay on the switches till platform starts tilting.

UP:

Step on switch 2 and hold – wait between one and three seconds before you step on switch 1.
 →The platform will tilt up to preset position before raising.

IF BOTH SWITCHES ARE NOT ACTIVATED
 WITHIN THREE SECONDS, START OVER.

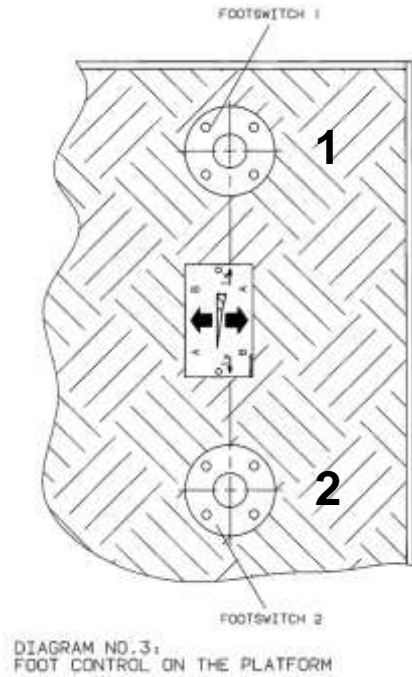

5.4 Operation by Wireless hand Held Remote (optional)

- 1) Power the remote using the ON/OFF switch on the rear of the control.
- 2) Each function has a separate button.
 Function is displayed on the button.
- 3) After finishing using the gate, switch the power OFF.

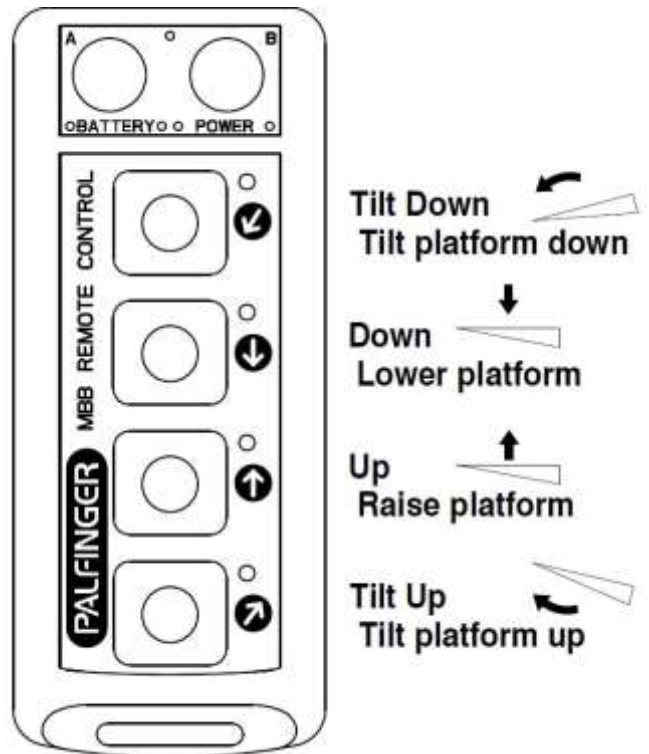

5.5 Application of the Liftgate for Dock Loading

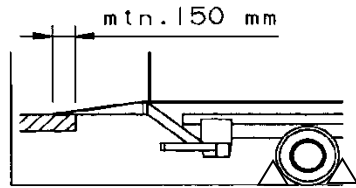

FIG. 1

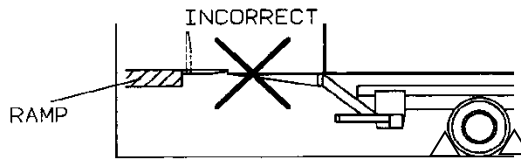

FIG. 3

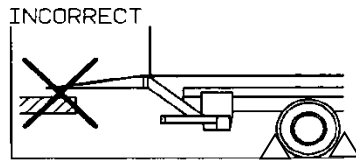

FIG. 2

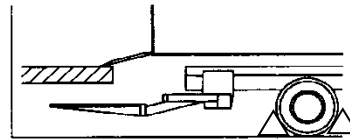

FIG. 4

DIAGRAM NO.5:
USING THE TAIL LIFT
AS A LINK BRIDGE

→ Move platform under the ramp and apply a cantilever drive-over dock plate (Fig. 4).



Always chock the wheels using Dock Loading



If not possible, there are other ways of loading:

- The platform must **sufficiently** overlap with the ramp to obtain safe loading surface (Fig. 1)
- When unloading, the rebound clearance of the vehicle is not compensated; therefore the platform must be re-adjusted (opened). Otherwise the tip of the platform can be overloaded, risk of serious damage is possible (Fig. 2)
- Never place drive-over plates or link bridge on the platform tip without supporting the tip. The platform tip must always be supported. (Fig. 3)



The maximum loads must be observed and followed.



6. Preventive Maintenance and Quick Check

The ILK Plus needs preventive maintenance to perform at its fullest capability. Lubricate and inspect regularly. Also, check that all details are not damaged: Hoses, cables, controls, etc.



REPAIR OR REPLACE IMMEDIATELY FAULTY PARTS



6.1 Maintenance and Care

The following inspection and maintenance should be performed at the recommended intervals depending on operation and amount of cycles or at the time when the unit shows any signs of damage or abuse. Remember that the secret to a long life of your PALFINGER Liftgate is to maintain it through preventive care.

* Recommended bases for inspection and maintenance	Depending on use	Daily	Monthly	Quarterly
cleaning	x			
general lubrication of pins and bushings				x
oil level inspection				x
oil change	x			
check hydraulic hoses and pipes for leaks				x
check controls and connections				x
check pins and pin retaining bolts			x	
check batteries and connections				x
check warning labels and other safety equipment for effectiveness and visibility		x		
visual check for loose or missing parts and un-usual noise during operation		x		
check lock bolts, mount plate bolts, and pins for tightness				x
check complete function of gate		x		
check mounting brackets of liftgate to frame for cracks or damage visually		x		

Table 1: Maintenance Schedule

6.2 Lubrication

Properly lubricated, the ILK Plus PALFINGER Liftgate will ensure longevity. Therefore, lubricate the liftgate at the same time as the truck/trailer. Grease more frequently if the liftgate is heavily used. The liftgate should be greased every 1200 cycles (depending on use – estimated every 3 month).

Check the oil level in the tank. The level should be between the two marks 5 and 7 when the platform is tilted down at ground level. Use a good quality of hydraulic fluid, ISO 32. Change oil at least once a year, preferably in the fall before the weather gets cold. The operation of the liftgate will accumulate condensation and some dirt which can interfere with the liftgate functions.

6.2.1 Lubrication Plan

All bearing points must be lubricated in accordance with the maintenance intervals.

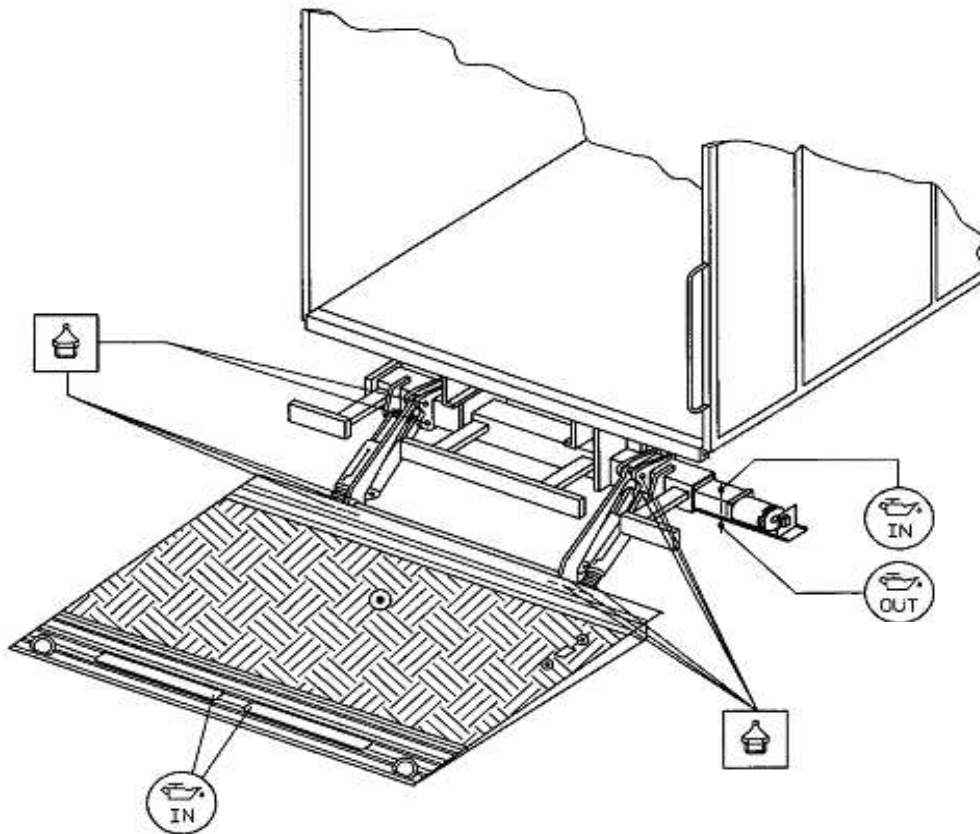

The gate has 12 grease zerks. On each side are 6 zerks.
3 in the mount frame area and 3 in the cylinder/platform area.

Figure 5: Lube Points



Lubricating nipple (6 on each side)



Oil level in the power pack tank (see marking inside of power pack reservoir)



Platform hinges and optional Cart Stops (use WD-40 spray for lubrication)

6.2.2 Checking and Changing the Oil

Check the quality of hydraulic fluid. If bad, take the following steps to change the oil. To begin, lower gate to ground and tilt platform down, remove lock bolt. Pull the power pack out till you can reach the oil filler cap. Unscrew the oil drainage bolt (bottom of tray) and let the fluid drain out of the reservoir into an approved container. When the reservoir is empty fill it up with hydraulic oil, as shown on table 2.

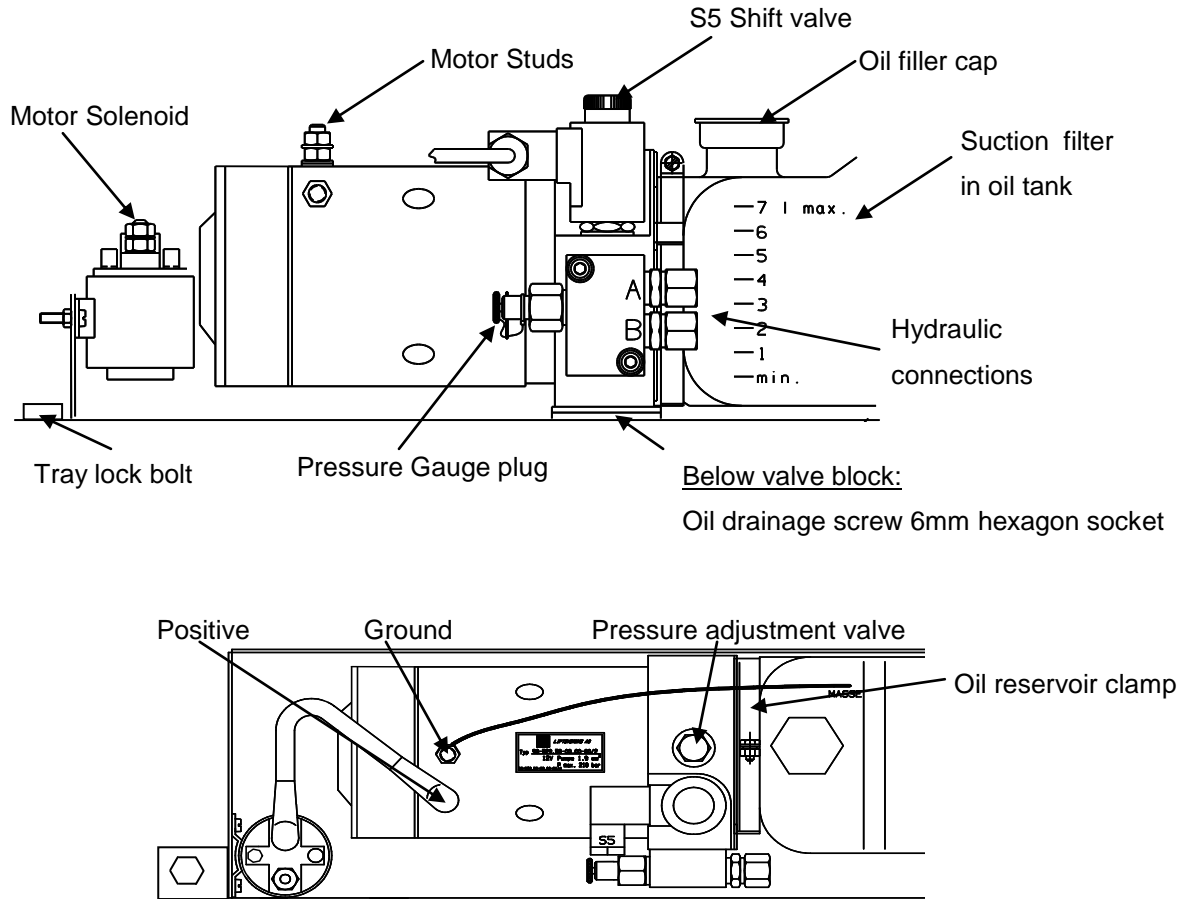

Figure 6: Power Pack (Side and Top View)

6.2.3 Recommended Hydraulic Fluids

<u>TEMP. RANGE</u>	<u>BRAND</u>	
-10 TO 150 F	EXXON	UNIVIS J26
	MOBIL OIL	DTE 13M
	CHEVRON	AW MV32
	ROSEMEAD	MV 150 (32)
-50 TO 150 F	MOBIL	DTE 13M
	SHELL	AERO FLUID 4
EXTREME COLD TEMPERATURE:	USE MILITARY SPEC:	MIL H5606

Table 2: Recommended Hydraulic Fluids

6.3 Decal Placement and Inspection

For operator's safety, all decals appearing in "Decal Kit" must be in a conspicuous place on control side of liftgate to be read by operator. This is typically a combination of decals on the liftgate and truck body. Please make sure to place the maximum capacity decal (C) on driver and curb side.

IMPORTANT: Never remove or paint over any decal.

- (A) 1 ATG-URGWA - Urgent warning: Elevating gate instructions
- (B) 1 ATG-ILK - Main Operation (Control Box)
- (C) 2 ATG-XXXX - Max. Capacity (please check the serial number plate to find out your specific capacity)
- (D) 1 ATG-CAB - Liftgate Shut-Off (must be placed next to the Shut-Off Switch)
- (E) 1 ATG-BKR - Circuit Breaker Reset (must be located at the circuit breaker)
- (F) 2 ATG-WLH - Warning: liftgate can crush
- (G) 2 ATG-CTN - Caution: Always stand clear of platform area
- (H) 1 ATG-RESET - Circuit Breaker Protection
- (J) 1 ATG-OPENILD - Notice for Open & Close
- (K) 1 ATG-FT - Notice for Foot Control (if applicable)
- (L) 1 85-0415-000 – Torque Specifications (Bolt On Mount Plates)



Decal - A



Decal - B



Decal - C



Decal - D

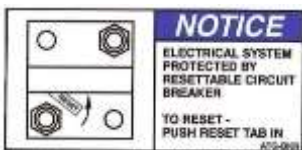

Decal - E



Decal - F



Decal - G



Decal - H



Decal - J



Decal - K



Decal - L

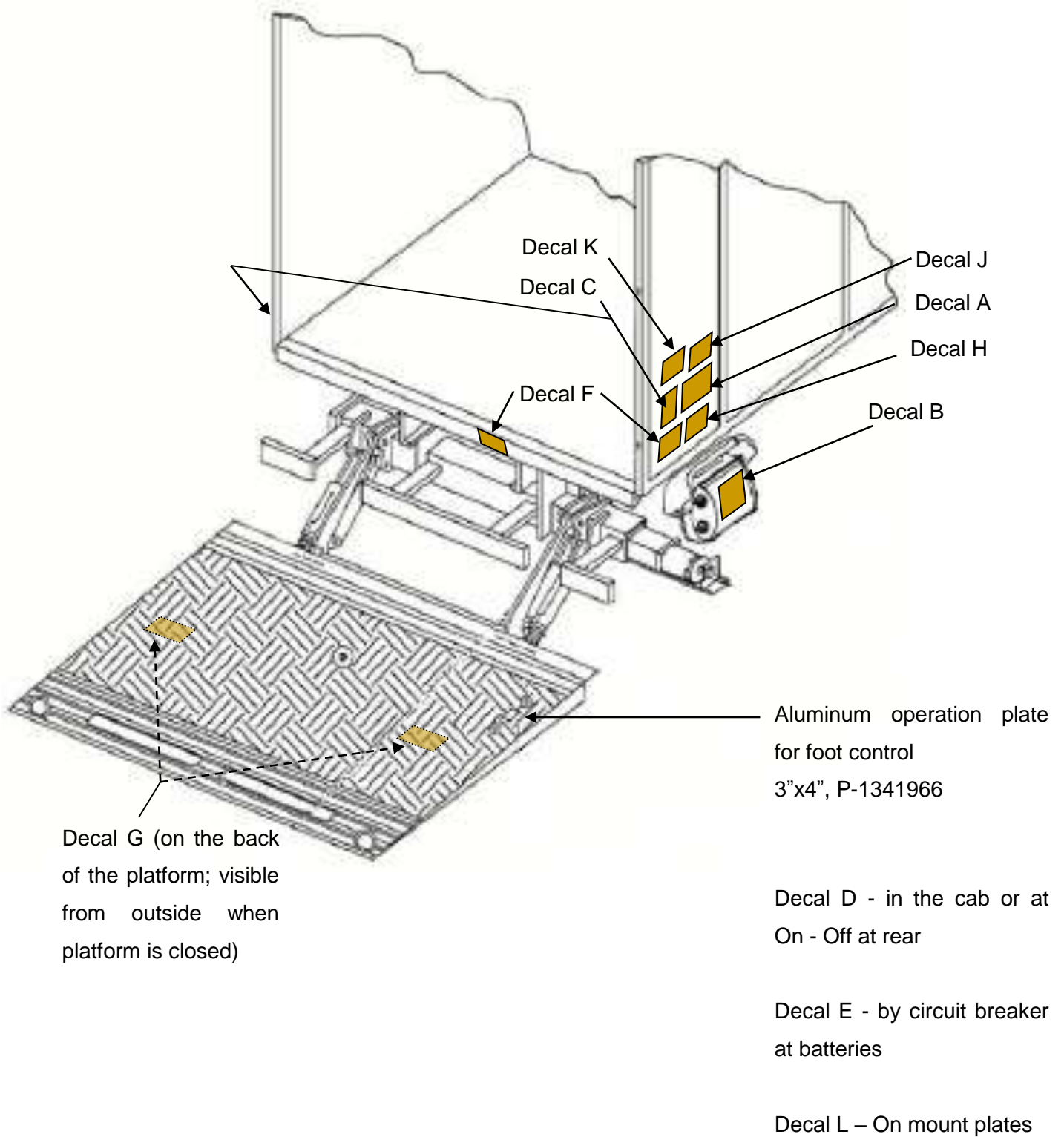

Figure 7: Decal Placement Guideline

6.4 Quick Check List

1. Operate the liftgate throughout its entire operation and check for noise and damage such as bent parts or cracked welds.
2. Inspect all welds and fasteners that attach the mount frame to the truck. All pins and bolts that connect the lift arm to the mount frame and to the platform.
3. Visually inspect the hydraulic lines for damage, scratches, bending or leakage.
4. Inspect the cylinders for leakage and that the cylinder pins are secured with lock bolts.
5. Check the oil level when the platform is down at ground level. The level should fall between the markings 5 and 7 on the tank. We recommend replacing oil after the first 500 cycles, after that on a yearly basis in the fall before winter begins.
6. Check for oil leakage around the HPU and inside mount tube. Tighten or replace components if needed. If you perform work on any hydraulic components bleed the air out of the system by operating all functions several times.
7. Check all electrical connections. Clean and protect battery terminals and check for tightness.
8. Inspect all the terminals on the solenoid-operated valves at the port of the cylinder. Lubricate the terminals for better protection from oxidation if needed.
9. Grease all zerks on the liftgate and make sure they all take grease. Sometimes it helps to operate the liftgate while you do this. There are 12 zerks.
10. Test all the liftgate functions.
11. Check the function of the pressure relief valve.
12. When doing daily checks and you find any kind of damage that can make the use of the liftgate dangerous, it must be repaired before using. All repairs should be made by an authorized technician. Use only original spare parts. If in doubt contact your PALFINGER Liftgates distributor or call PALFINGER Liftgates directly.



Do not cover up any accidents or damage; it can be dangerous for you and your co-workers.

7. Troubleshooting

ATTENTION:



Please check the following points before looking for faults:



Dangerous injuries possible from tools short circuiting main battery connections.



Every time you are finished troubleshooting, close the rubber cover on the curbside of the mount frame. **REINSTALL THE PLASTIC STRAP ON THE RUBBER COVER WHEN FINISHED!!**

- Please change oil after working on hydraulic unit (removal of valves, opening of cylinder etc.)
- There is a possibility of injury if somebody other than an authorized technician works on the electrical system!
- Injuries are possible if short circuits are caused by tools on the main battery connections.

7.1 Basic Function Check

7.1.1 LIFTGATE is completely DEAD (No Clicking or Movement at all)

1. Check the cab shut off switch .

Turn on cab switch, located in the cab next to the steering wheel. Location may vary by model and year of truck. Switch has L.E.D. lights: they should stay on continuously. On trailer units, you will find the switch on the control box to activate the gate.

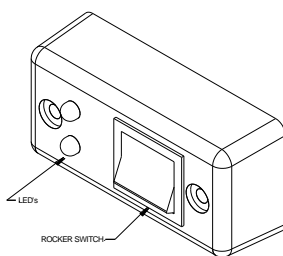

In Cab ON/OFF Switch (Truck)

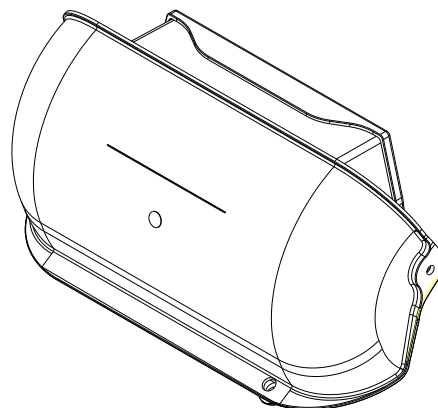

ON/OFF Switch (Trailer)

2. Check the circuit breaker at the main batteries.

Every truck has a circuit breaker on top of the main battery. If you have a studio unit, or a trailer, you will also find an auxiliary battery kit as shown in the pictures below ("Truck Battery" and "Auxiliary Battery"). If circuit breaker reset arm is popped out, push it back in as shown on the decal ATG-BKR next to your breaker or on battery box lid.

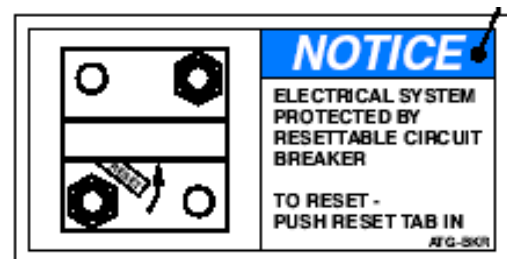
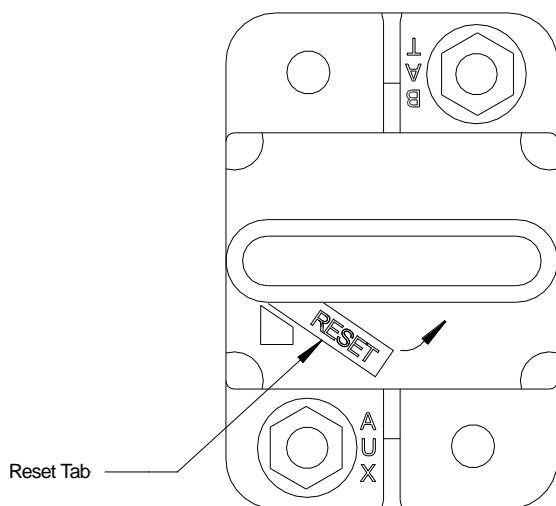
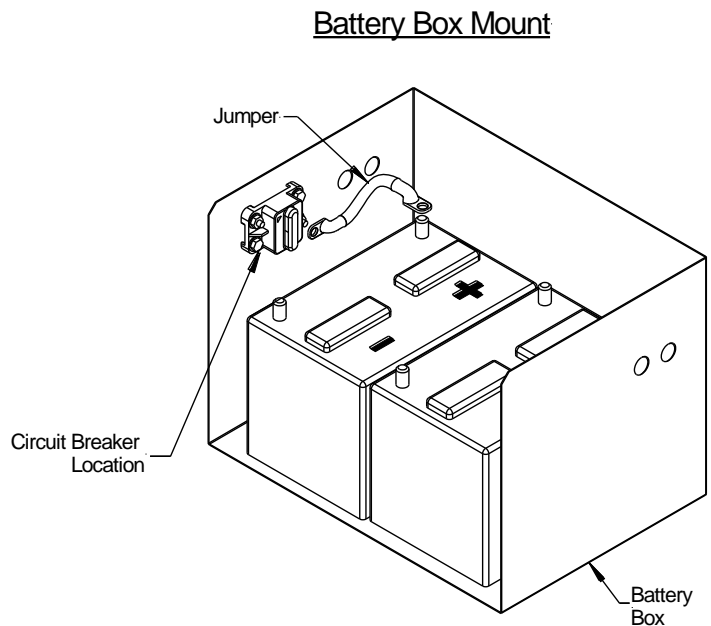
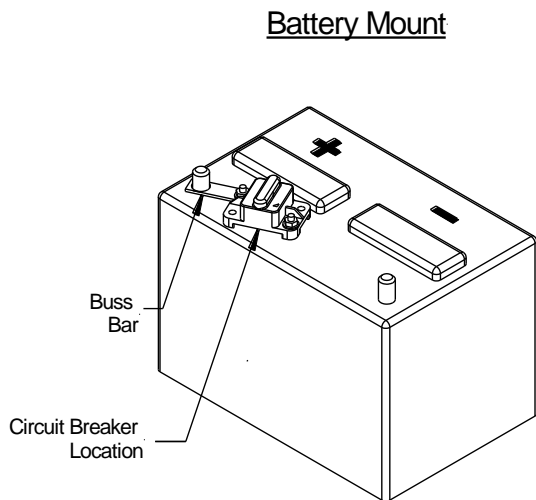

Circuit Breaker Needs to be Reset when Reset tab is exposed

3. Are the vehicle batteries charged?

Check batteries and the truck/trailer charging system. Start truck and run engine in fast idle for charging the batteries. If liftgate starts working, recharge batteries.

4. Check the fuse at the power pack and battery.

The control board has two 15 Amp fuses and at the battery there should be a 20 Amp fuse. Check all fuse holders for blown fuse(s) and replace each blown fuse with the same amperage



DO NOT use higher amperage fuse.

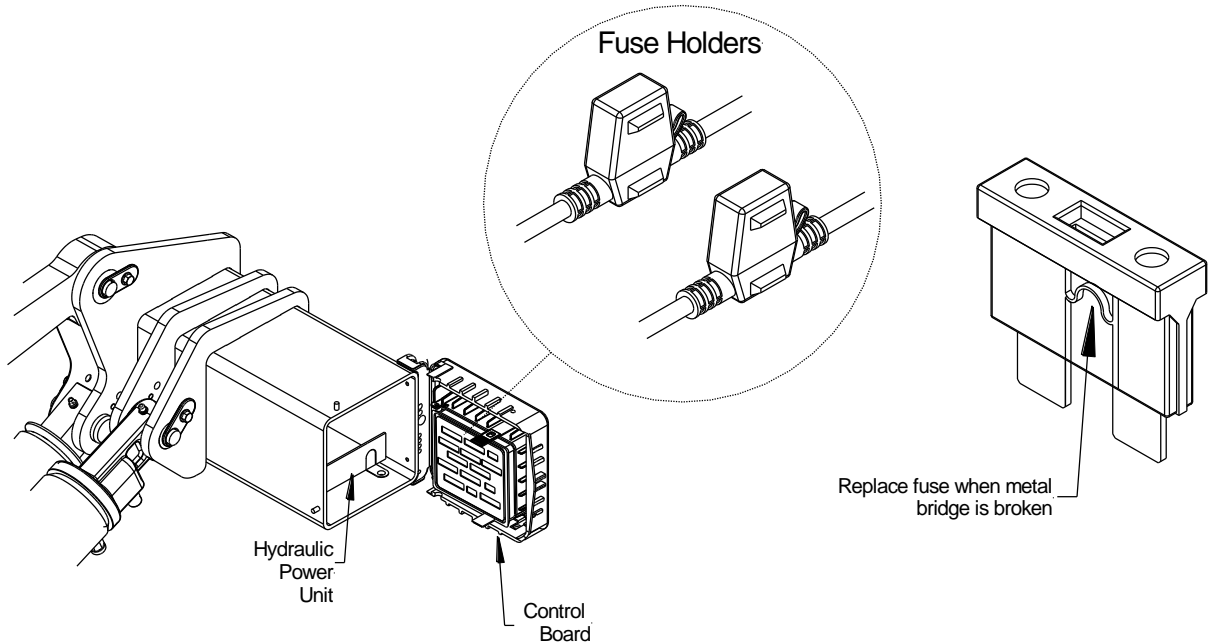

5. Is the connection to ground in power pack OK?

Is the ground connection from the liftgate to vehicle OK?

6. Check the oil level in the power pack reservoir.

The Hydraulic Power Unit is located inside the mount tube. To access the oil reservoir, remove the screw and slide out the Power Unit until there's access to the oil reservoir. Check the oil level is between the 5 and 7 marks.

7. Are there any damages on mechanical or electrical parts (such as damaged cables)?

7.1.2 On-Off L.E.D.s are on but all functions are dead

Possible malfunctions:

1. Short in hand held remote or its wire → remove plug J-31.
2. Short in control box wire → remove plug J-30.

After disconnecting plugs – reboot board by unplugging J-1 for 5 seconds and plug it back.

7.1.3 L.E.D.s continue to stay on, after switch is turned off

- Make sure platform is closed and stored vertically.
- Adjust the B-15 switch.
- B-15 is not working → unplug J-41 (gate operates without sensor but loses auto-tilt).

B-15 adjustment:

- one of the holes in the B-15 switch is oblong
- adjust the switch so it shuts off when platform is vertical

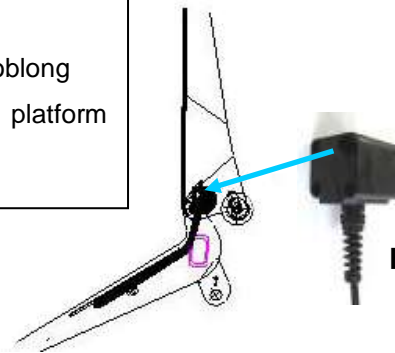

Make sure, the wire strain relief is always parallel with top of the platform.

B-15 Sensor

7.1.4 Platform tilts down before it reaches the ground

- Adjust B-13 lift arm switch. Set the switch in a horizontal level when the platform is 10" off the ground.
- B-13 is not working → unplug J-41 (gate operates without sensor but loses auto-tilt).

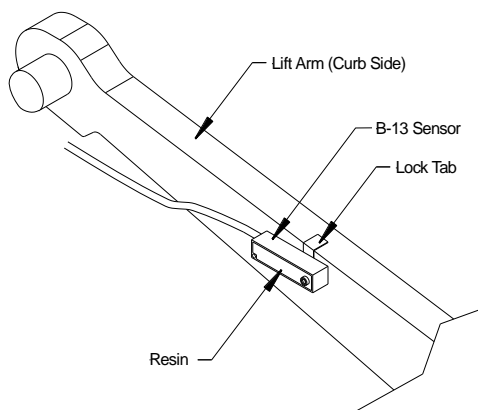

If gate is still not working, take Truck/Trailer to a repair station.



7.2 Possible cause & remedy of liftgate malfunction

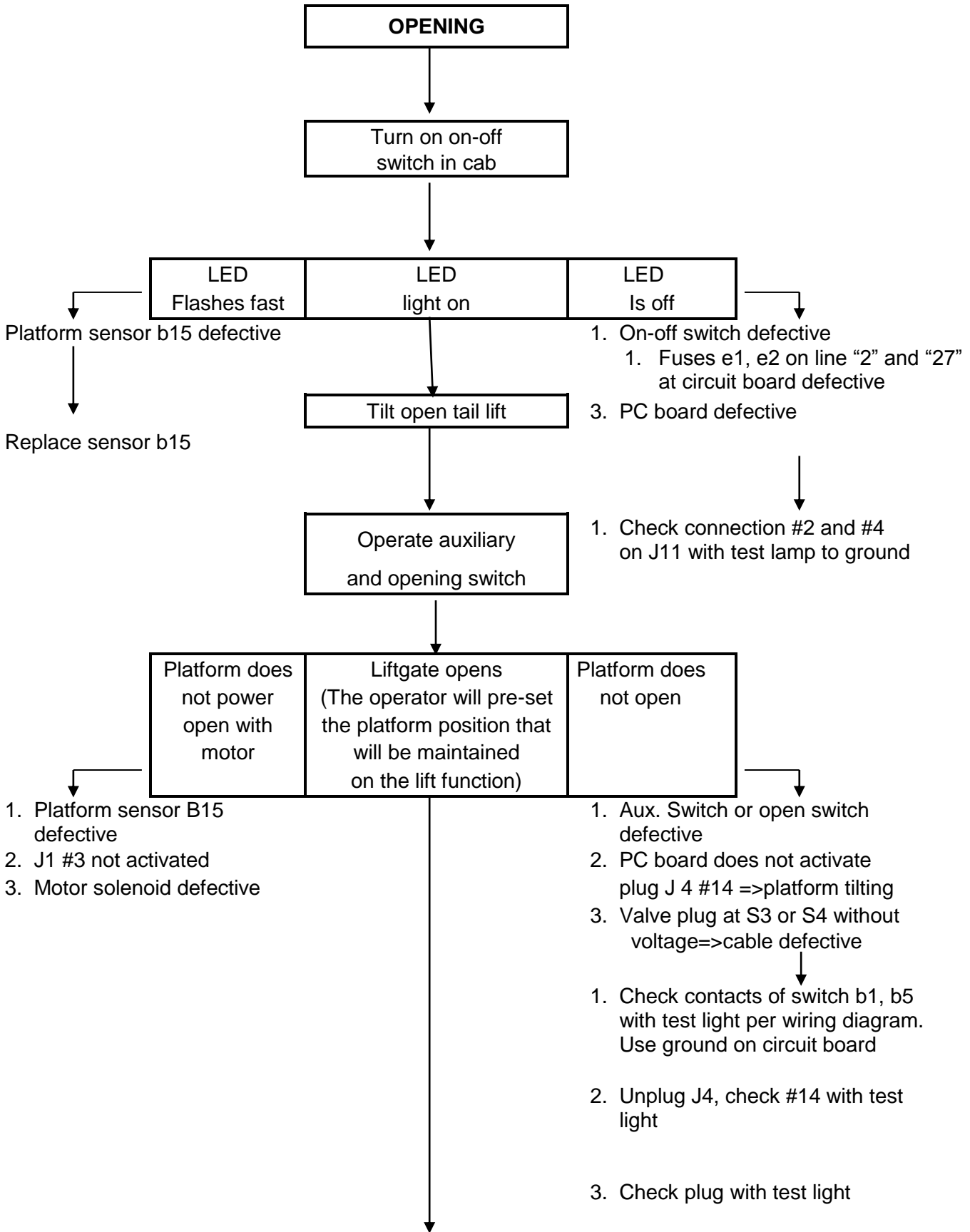

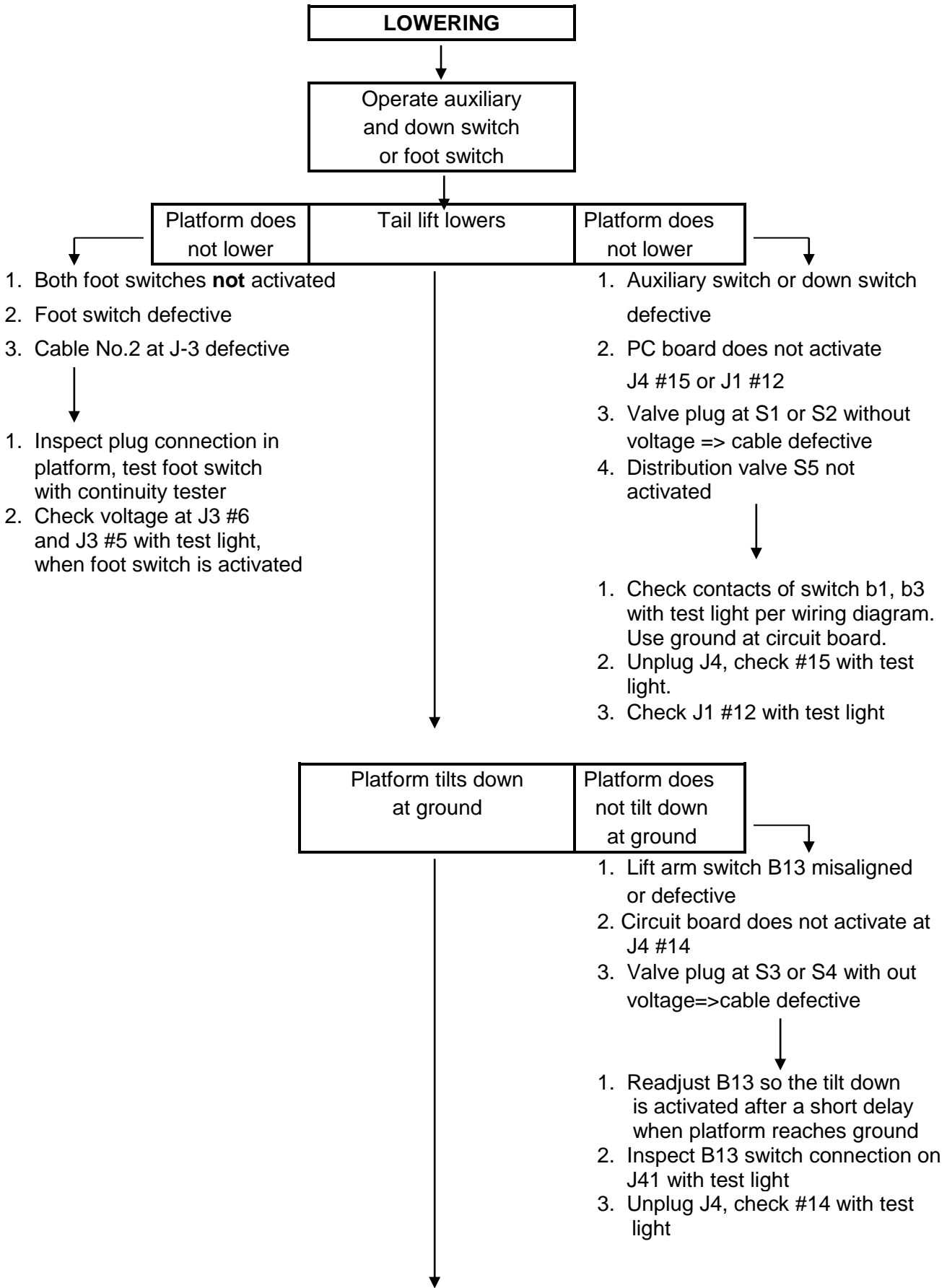

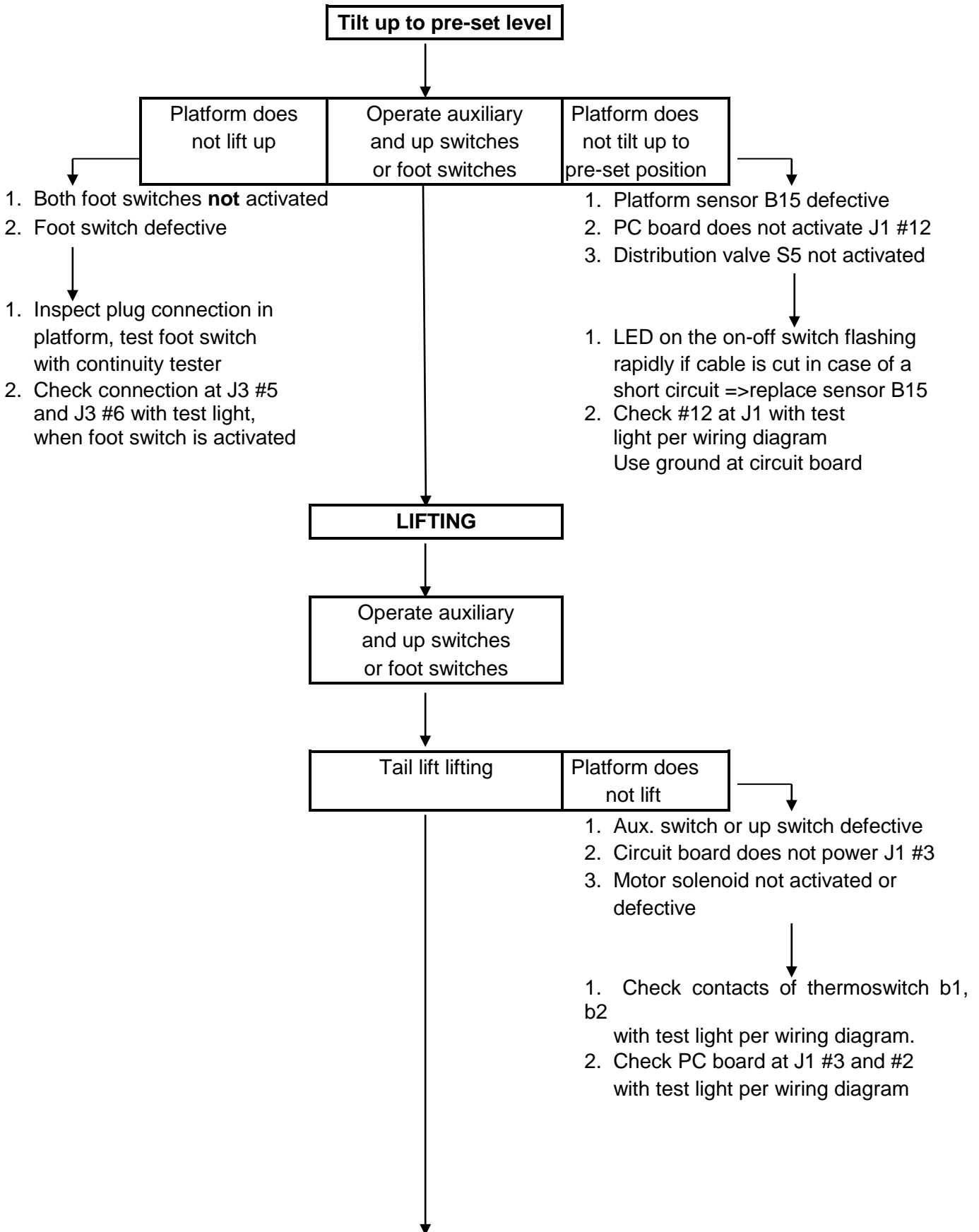

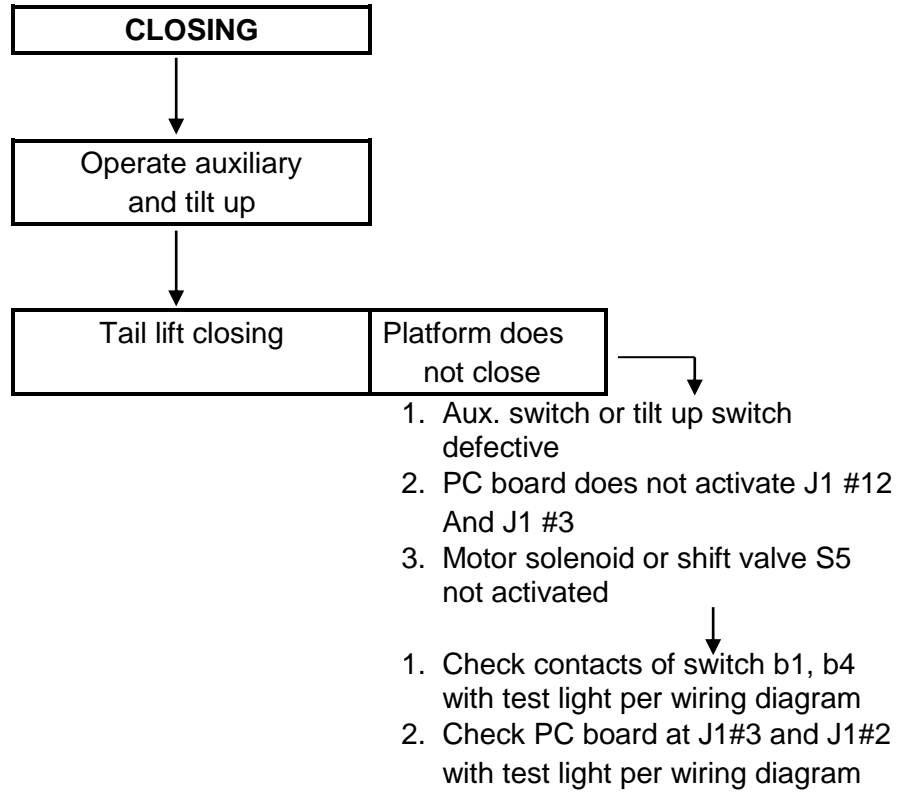

7.3 Electrical and Hydraulic Schematic

7.3.1 Wiring Diagram - Truck

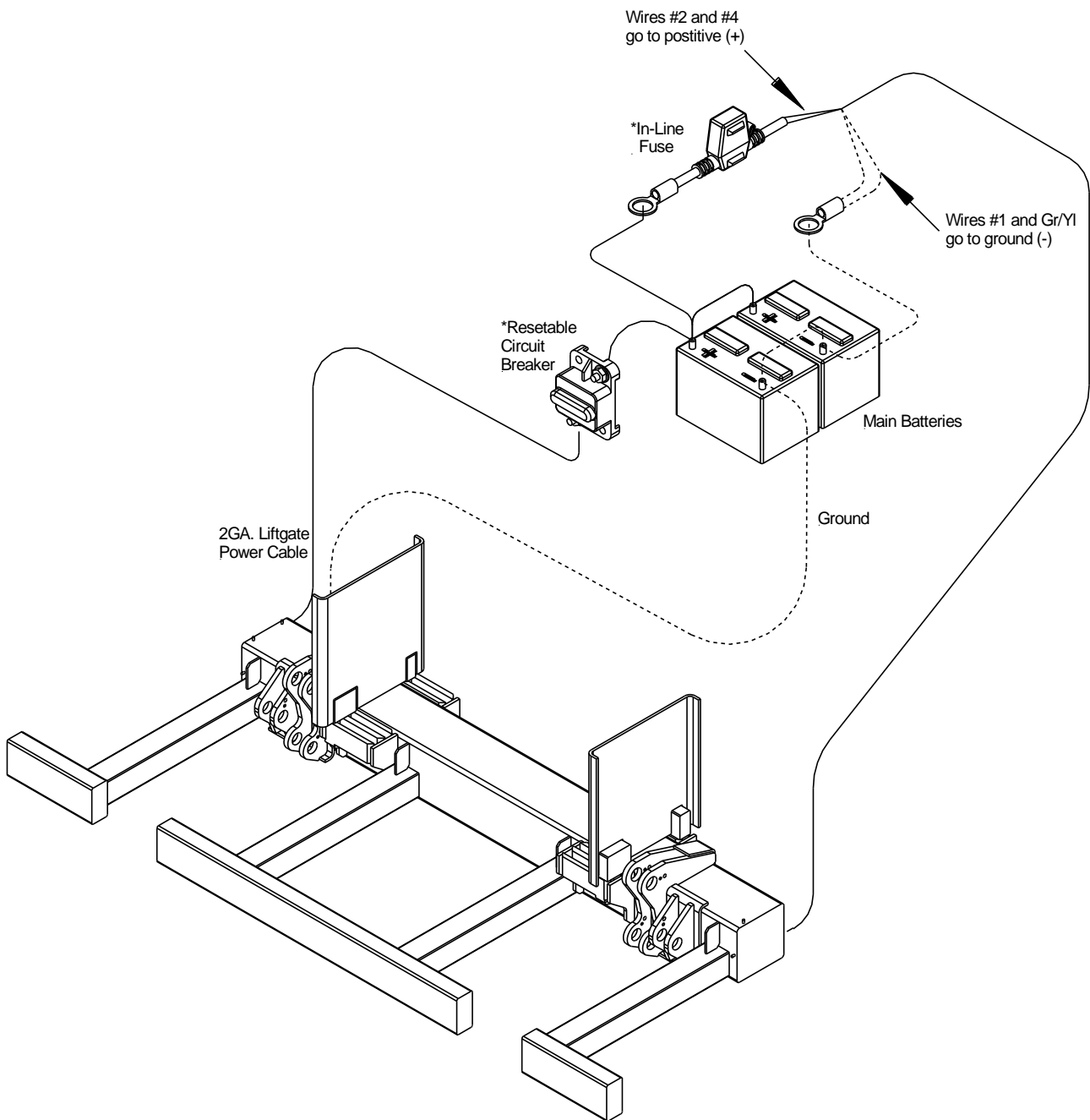

*In-Line ATC Fuse: 20 Amp. **Replace with same amperage fuse when necessary.**
 Resettable Circuit Breaker: 150 Amp Min. **Replace with same amperage breaker when necessary.
 ***Ground: For optimal grounding, ground all batteries and power units to the body side rails of the vehicle.
NOTICE: DO NOT attempt to jump in-line fuses with other objects other than the specified fuse. Do not increase the amperage rating of fuse. Serious harm to the liftgate will result when standard practices are not followed.

Truck Wiring Diagram

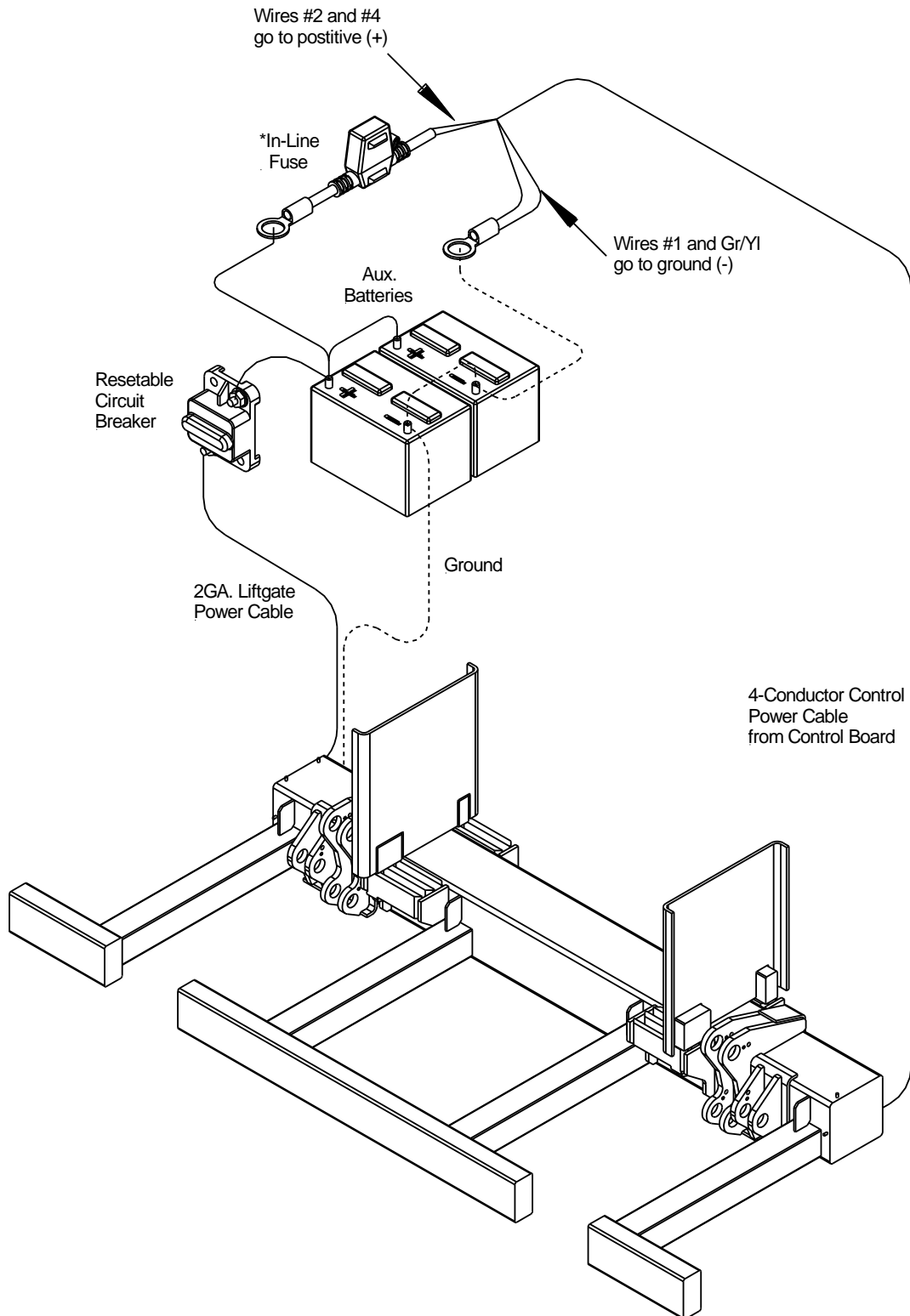

*In-Line ATC Fuse: 20 Amp. **Replace with same amperage fuse when necessary.**
 Resettable Circuit Breaker: 150 Amp Min. **Replace with same amperage breaker when necessary.
 ***Ground: For optimal grounding, ground all batteries and power units to the body side rails of the vehicle.
NOTICE: DO NOT attempt to jump in-line fuses with other objects other than the specified fuse. Do not increase the amperage rating of fuse. Serious harm to the liftgate will result when standard practices are not followed.

Trailer Wiring Diagram

7.3.3 Connector Overview

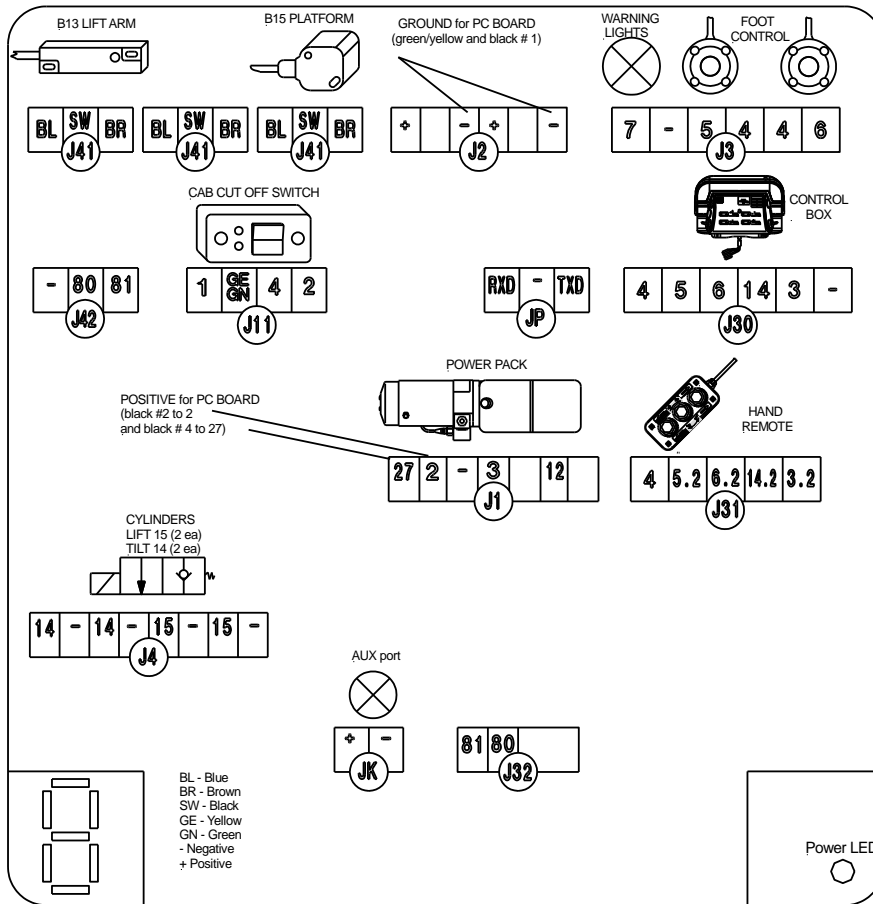

Control Board Codes:

Code	Description	Reset
0	System ok / Cab switch off, (or missing bridge J11/2<->4)	
1	System ok / Cab switch on, (or bridge J11/2<->4)	
2	Low Voltage	Cab switch: off/on (or disconnect bridge J11/2<->4)
3	Missing tilt switch B-13 at lift arm or defective.	Automatically when the valves are back to normal
4	Missing tilt angle sensor B-15 at lift platform or defective	Automatically when the valves are back to normal
5	Missing tilt angle sensor B-15 at platform or defective	Automatically when the valves are back to normal
6	Warning lights shorted	Cab switch: off/on (or disconnect bridge J11/2<->4) or close tail lift
7	Short in cab switch/on-off switch or aux port	Cab switch: off/on (or disconnect bridge J11/2<->4) or close tail lift
8	General short in electrical wiring	Cab switch: off/on (or disconnect bridge J11/2<->4) or voltage interruption MBB control
9	Defect at motor solenoid detected during lifting	Automatically when the valves are back to normal
A	Voltage V02 (J1 pin 2) is missing, defective fuse	Replace the fuse
B	Defect at opening, valve (S3/S4) or motor relay detected during opening	Automatically when the valves are back to normal
C	S5 valve detected during closing or motor solenoid defective	Automatically when the valves are back to normal
D	S5 valve detected or defect at lowering valve (S1/S2)	Automatically when the valves are back to normal
E	Emergency program (all sensors are bypassed). Activation by: Press Open+Lower>10 seconds	Cab switch: off/on (or disconnect bridge J11/2<->4)
P	Diagnosis mode activated	Removing service connector

Figure 9: Connector Overview

7.3.4 Hydraulic Schematic

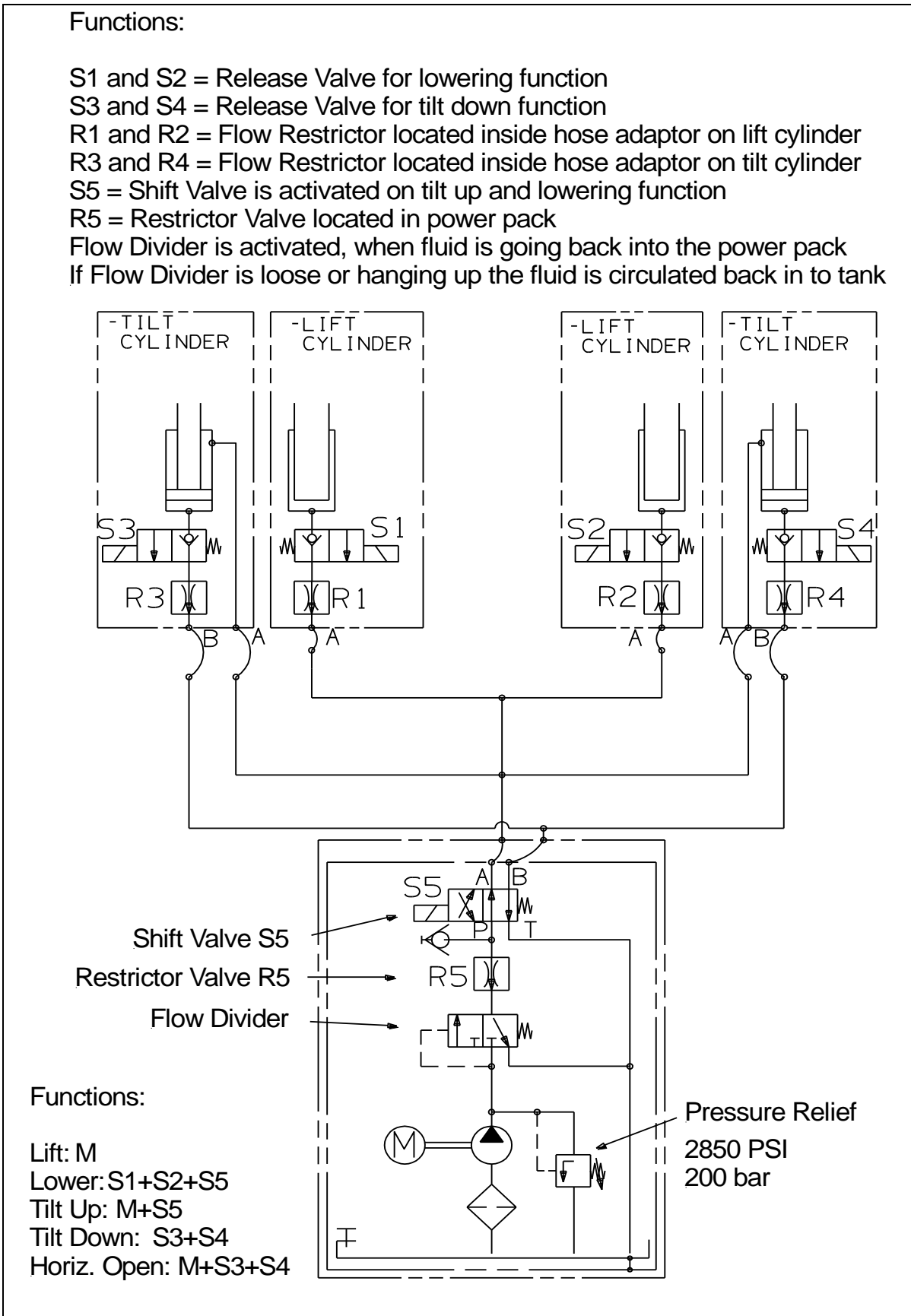

Figure 10: Hydraulic Schematic

Needed Information for Ordering Spare Parts and Repairs

7.4 Ordering Spare Parts

In order to assure quick delivery of spare parts, please always state the following information when making orders:

1. Liftgate model & serial number.
2. Designation and number of the spare part in accordance with the spare parts list.
3. Designation and number marked on the individual component (if available).

7.5 Repairs

Parts sent to PALFINGER Liftgates to repair must be accompanied by a letter (in separate cover) giving details and scope of the repairs required.

8. Warranty

PALFINGER Liftgates provides warranty as part of its conditions of delivery.

Spare part deliveries are first of all billed. PALFINGER Liftgates issues credit for all or part of the invoiced sum when PALFINGER Liftgates has been able to determine that the warranty claim is justified as defined by its warranty conditions. PALFINGER Liftgates does this by inspecting the defected parts which are sent back to PALFINGER Liftgates freight-prepaid as well as the written description of the problem which must have been filled out in full.

The parts that are sent back to PALFINGER Liftgates, marked with serial number and address, become PALFINGER Liftgates' property if the warranty claim is accepted.

All warranty claims must be received **within 30 days** of repair or replacement. Including the following information:

1. Liftgate model.
2. Liftgate serial number.
3. Description of problem.
4. Itemized bill of repair with break down of number of hours to perform warranty work and labor charges per repair.
5. Parts used for repair with PALFINGER Liftgates part number.
6. RMA#.
7. Contact at PALFINGER Liftgates, if applicable.

Model	Pump and Motor	Cylinders	Hardware	Control System	Hydraulic
ILK Plus	2 yr	3 yr	3 yr	2 yr	2 yr

Table 3: Warranty Coverage Schedule¹

¹ Effective: Aug. 2010

9. Contact Address



15939 Piuma Ave
Cerritos, CA 90703
Phone: (562)-924-8218
Fax: (562)-924-8318

E-mail (parts order):
liftgateparts@palfinger.com

E-mail (technical support):
technicalapplications@palfinger.com



572 Whitehead Road
Trenton, NJ 08619
Phone: (609)-587-4200
Fax: (609)-587-4201

E-mail (parts order):
liftgateparts@palfinger.com

E-mail (technical support):
technicalapplications@palfinger.com