

**PALFINGER**

**SOLID | TECHNOLOGY**

# **ONE STEP AHEAD THE NEW SLD & TEC HOOKLOADERS**

**LIFETIME EXCELLENCE**



# NEW GENERATION OF PALFINGER HOOKLOADERS

PALFINGER presents its new generation of hookloaders. The models provide new functions and solutions while maintaining an optimal dead weight. The mechanical design was optimised to facilitate easier integration onto the chassis.

The development of this next generation of models brings with it the introduction of the new SLD and TEC ranges.

The introduction of the new product range for PALFINGER hookloaders, allows a clear differentiation according to technical features.

The SLD hookloaders are robust and easy to use.

The TEC models provide comfort, innovation and connectivity.

## SLD – SOLID RANGE

### Robust & easy to use

The SLD hookloaders are optimised to meet the essential needs of the customers.

They distinguish themselves through their ease of operation and quick commissioning as well as a robust and reliable mechanical structure.

The SLD range is currently available as SLD 3 and SLD 5.

- SLD 3 – Focused on essentials
- SLD 5 – Flexibility and adaptability

Example:

PH T 20 SLD 5 – a hookloader equipped with a PAD control, as well as bi-speed and soft stop function.

#### Models:

PH T 18 SLD 5	PH T 20 SLD 3	PH T 22 SLD 3
PH T 18A SLD 5	PH T 20 SLD 5	PH T 22 SLD 5
	PH T 20A SLD 5	PH T 22A SLD 5



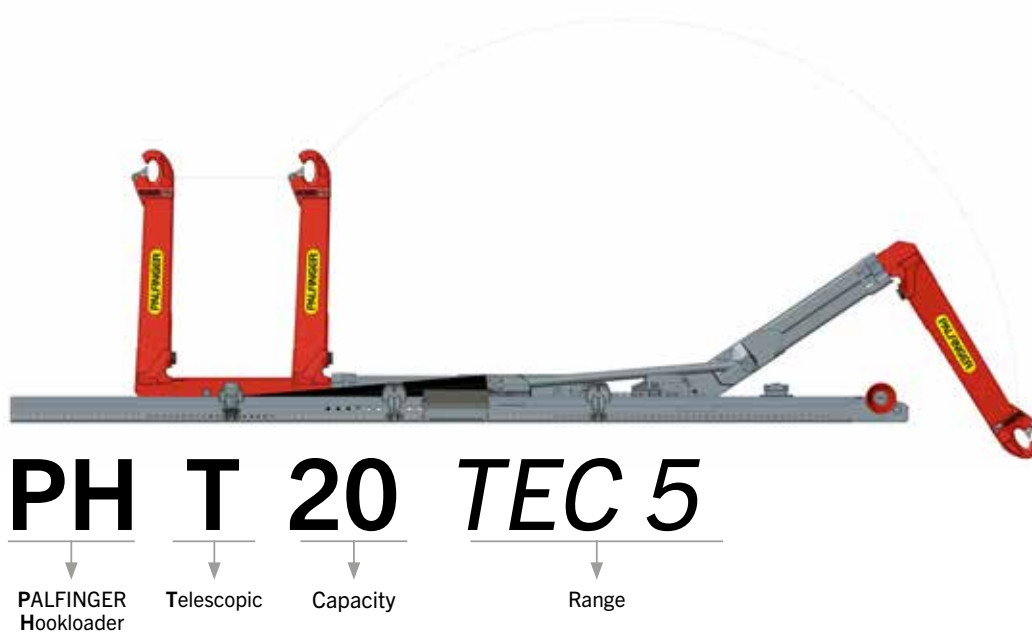

# TEC – TECHNOLOGY RANGE

## Innovations & intelligent functions

The hookloaders within the TEC range distinguish themselves through their increased operational comfort. They are equipped with the new innovative PAD-Touch control, camera-assisted Pack Vision as standard and benefit from new intelligent functions developed by PALFINGER. The TEC hookloaders meet individual customer requirements, resulting in a level of flexibility that spans a wide range of applications. The use of bolted solutions facilitates ease of maintenance as well as the flexibility to add more options and functions.

The TEC range is currently available as TEC 5 .

- TEC 5 – Innovation and connectivity

Example:

PH T 20 TEC 5 – a hookloader equipped with a PAD-Touch control and camera-assisted Pack Vision.

### Models:

PH T18 TEC 5	PH T 20 TEC 5	PH T 22 TEC 5
PH T 18A TEC 5	PH T 20A TEC 5	PH T 22A TEC 5



