

ETC MH 45 IH

ARTICULATED / TELESCOPIC
INSULATED MATERIAL HANDLING



INSULATED VERSATILITY

The ETC MH 45 IH is a versatile insulated unit that is well suited to those customers in need of an aerial unit that can offer powerful capabilities. With an articulating and telescoping aerial lift that reaches a height of 45' to the bottom of the bucket, this unit has standard continuous rotation allowing for unrestricted rotation. This model also offers material handling capabilities with a hydraulic winch and a 5' jib that can lift up to 1,000 lbs.



DEPEND ON IT.™



ETC MH 45 IH

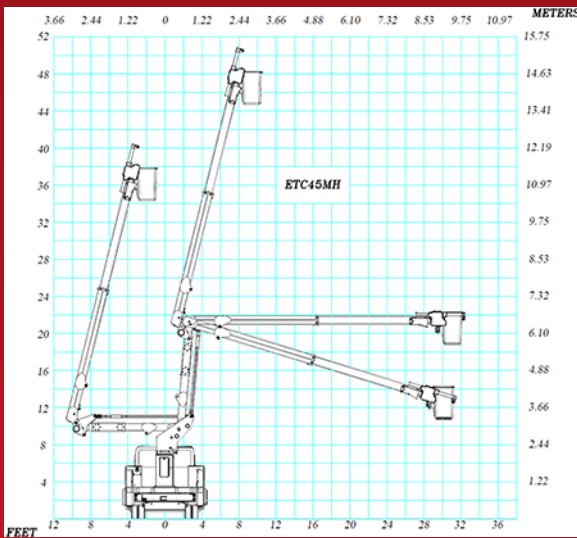

EQUIPMENT TECHNOLOGY LLC IS A FULL SERVICE SOLUTION PROVIDER OF THE HIGHEST QUALITY DESIGN, MANUFACTURING, AND POST SALE SERVICE.

EQUIPMENT TECHNOLOGY LLC

341 NW 122nd
 Oklahoma City, OK 73114
 Toll-Free: 1-888-748-3841 • Fax: 1-405-755-6829
 etiequipment.com

GENERAL SPECIFICATIONS*

- Height to bottom of bucket 45 ft
- Working height 50 ft. - 0 in.
- Side reach, End mount 32 ft. - 3 in.
- Rotation Continuous
- Lower boom articulation 0 to 95 degrees
- Upper boom travel -17 to 76 degrees
- Stow height 11 ft. - 4 in.
- Rated bucket capacity 500 lbs.

MINIMUM VEHICLE SPECIFICATIONS

- GVWR 23, 500 lbs.
- C.A. 84 in.

STANDARD FEATURES

- Fiberglass Inner Boom
- Hoses Inside Boom are contained in a cat trac
- 18 gallon oil reservoir
- Lower Boom Insert
- Bucket with Center Step
- Outrigger/boom interlock
- Hydraulic Jib and Winch Package
- 450 lbs. minimum capacity - up to 1,000 lbs maximum capacity
- Hydraulic Tilting Jib Mounted on Side of Boom
- Hydraulic Winch Mounted Under Jib
- 60' x 1/2" winch line with swivel hook
- Remote Winch Control at Lower Controls
- Manual jib extension
- Manual emergency decent valve
- Single handle control at bucket

OPTIONS

- Engine start/stop at bucket
- Emergency hydraulic power (12VDC)
- Hydraulic tool circuit
- Bucket liner
- Bucket cover
- Hydraulic Jib Extension
- Platform Elevator



Specifications are subject to change without notice