

ETT 29 SNV—Cable Splicer Package Mercedes-Benz 2024 Sprinter Van 3500



MERCEDES-BENZ

ETT 29 SNV—CABLE SPLICER PACKAGE  
2024 SPRINTER VAN 3500

NEW

AVAILABLE

IMMEDIATE DELIVERY



OFFER INFORMATION

Location details

341 NW 122nd Street, Oklahoma City, OK, 73114 -  
United States 

Dealer Name

PALFINGER

Availability

Available

Product type

New

Contact person

Richard Holley

Dealer E-mail

r.holley@palfinger.com

Dealer phone

+1-405-210-4368

**\$136,500.00**

## AERIAL UNIT DETAILS

ETT29SNV

- 34 ft Working Height
- 20'6" Side Reach
- Non-Insulated Boom
- 24x30 Platform
- 350 Bucket Capacity

## BODY DETAILS

- Sprinter Body
- Fiber Splicer Unit Setup
- Onan 5000W
- Dual-Therm Air conditioner
- Dimension 1800 Watt Inverter
- Fiber Splicer table with Rear Splicer window

## CHASSIS DETAILS

- 2024 Mercedes - Benz Sprinter Van 3500

**PALFINGER**

# ETT 29 SNV

ARTICULATED/TELESCOPIC — NON-INSULATED



# ETT 29 SNV



## OPERATIONAL ZONE

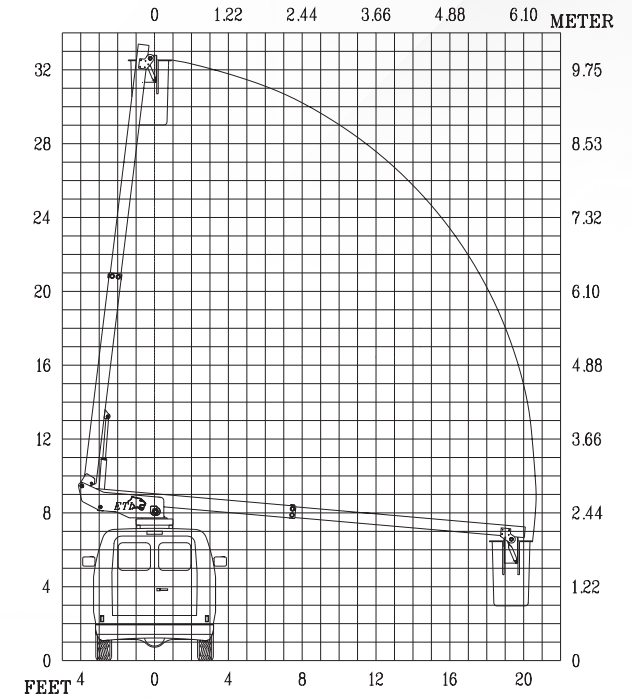

PALFINGER's innovative ETT 29 SNV is a van-mounted non-insulated aerial unit with a hydraulic platform leveling electric over hydraulic upper and lower controls. Features include an oversize-bucket and door, an extended gear shaft for manual rotation, ground-accessible controls, replaceable pin bushings, and adjustable wear pads.

<b>GENERAL SPECS:</b>	Height to Bottom of Bucket	Working Height	Side Reach End Mount	Stowed Height	Rated Bucket Capacity	Rotation
	Side Mount (Standard): 20' 6" End Mount: 22'	Side Mount (Standard): 33' 7" End Mount: 34'	Side Mount (Standard): 20' 9" End Mount: 22' 9"	9' 3"	300 lbs.	390° Non-Continuous
<b>OPTIONS:</b>	Emergency hydraulic power (12VDC)	Bucket liner	Bucket cover	DC power options, including cab comfort		
<b>MINIMUM VEHICLE REQUIREMENTS:</b>	GVWR (dual rear wheels)	C.A.	ANSI			
	8,500 lbs.	138 in.	Non-Insulated			

PALFINGER North America, LLC.

341 Northwest 122nd St | Oklahoma City | Oklahoma | 73114 | +1 888 748 384 | PALFINGER.COM

\*All specifications are based on the 40" frame height and subject to change without notice. Bucket trucks shown in this brochure are partially optional equipped and do not always correspond to the standard version. Country-specific regulations must be observed. Dimensions may vary. Subject to technical changes, errors and translation mistakes.